

## MT5000

# Guided Wave Radar Level Transmitter

State-of-the-art loop powered,  
4-20 mA output guided wave  
radar transmitter for liquid level  
applications

K-TEK Products



### Introduction

This operating instruction manual provides the following information:

- Installation instructions—see page 6
- Commissioning guidelines—see page 8
- Troubleshooting—see page 32
- Installation drawings—see page 34
- CE certificate of conformity – see page 41

# TABLE OF CONTENTS

1.0	Introduction .....	3
2.0	Overview .....	4
2.1	Storage and Handling Information .....	4
2.2	Ambient Temperature .....	4
2.3	Description and Principle of Operation.....	4
3.0	Installation.....	6
3.1	Mechanical Installation.....	6
3.2	Shortening of the Probe .....	7
3.3	Electrical Installation .....	7
4.0	Commissioning .....	8
4.1	Display Operation.....	8
4.1.1.	Jumper Settings .....	9
4.1.2.	Push Buttons.....	9
4.2	MT5000 Menu Flow Chart.....	10
4.3	Basic Setup.....	11
4.3.1.	Units.....	11
4.3.2.	Probe Type .....	11
4.3.3.	Probe Length .....	12
4.3.4.	Mounting Type .....	13
4.3.5.	Nozzle Length .....	14
4.3.6.	Offset .....	14
4.3.7.	Dielectric .....	16
4.3.8.	Measure Mode .....	16
4.3.9.	Language .....	17
4.4	Quick Calibration.....	18
4.5	mA Output Setup .....	18
4.5.1.	Output .....	19
4.5.2.	LRV 4mA.....	19
4.5.3.	URV 20mA.....	19
4.5.4.	Dampening.....	20
4.5.5.	Alarm Delay .....	20
4.5.6.	DAC Trim (4mA and 20mA) .....	21
4.5.7.	LOOP Test.....	21
4.5.8.	HART Address.....	22
4.5.9.	LRS (HART version only).....	22
4.6	Extended Setup .....	23
4.6.1.	Waveform Display .....	23
4.6.2.	Functions .....	25
4.6.3.	Temperature .....	26
4.6.4.	Linearization Menu.....	27
4.6.5.	SOR (HART version only).....	31
5.0	Safety, Maintenance and Troubleshooting.....	32
5.1	Personnel Qualifications .....	32
5.2	Required Tools.....	32
5.3	Suggested Proof Test .....	33
5.4	Safety Inspection & Test.....	33
5.5	Verify Proper Power-up of the Transmitter.....	36
5.6	Module Replacement or Upgrade.....	36
5.7	Valid current loop outputs.....	37
5.8	Troubleshooting Symptoms and Solutions.....	37
5.9	Electronics Module Replacement.....	37
6.0	Installation Drawings for Intrinsic Safety & Standard Wiring .....	38
7.0	Installation Drawings for Explosion Proof.....	40
8.0	CE Certificate of Conformity.....	41
9.0	Customer Support.....	42
9.1	ABB RMA Form .....	43
10.0	Warranty .....	44

## 1.0 INTRODUCTION

Thank you for using the ABB MT5000 Guided Wave Radar Liquid Level Transmitter. The MT5000 series is a second generation of products which have been designed for simplicity of setup while offering extensive configuration capabilities. You are invited and urged to review this instruction manual in its entirety prior to use of the transmitter. This will eliminate most installation problems due to improper configuration.

We, the ABB Family, sincerely hope you receive many years of reliable use from the MT5000 transmitter and welcome your feedback to consistently improve our all of our products. It is our desire to provide you, the user, with the most reliable, customer friendly device to suit your application needs.

When it comes to measuring the level of liquids, guided wave radar technology now offers more level-detection capabilities than ever before. For an ever-widening range of previously hard-to-measure products such as molten sulfur, liquid ammonia and petrochemicals, guided wave radar transmitters provide accurate level measurements even under harsh chemical environments, wide variations in operating temperatures and pressures, and low dielectric constants. Great strides have also been taken in making these units easier to configure to a variety of process applications coupled with the simplicity of integrating these devices with most digital communication protocols. These improvements come as a welcome relief to process engineers that seek solutions to measuring the contents of tanks, silos, hoppers, bins, mixing basins, and vessels in an expanded range of level applications across several different industries.

Because a guided wave radar transmitter has no moving parts, it has established itself as a level measurement technology that has distanced itself from traditional mechanical means, which don't hold up as well in dirty service. Guided wave radar achieves its non-mechanical level detection capability by measuring the time of flight of the transmitted signal.

Known more accurately as Time Domain Reflectometry (TDR), the process involves:

1. Sending microwave energy down into a vessel guided by an antenna.
2. When the pulse of radar energy reaches the product (indicated by a change in impedance), part of the pulse is reflected back toward the transmitter.
3. A receiver measures the exact duration of time between the transmitted and reflected signal—the "time of flight."
4. The device analyzes this time and ultimately displays the level of the product as a distance in inches, feet, meters, or other engineering units.

The MT5000 transmitter was developed with ease of operation in mind. We made use of a graphic display to provide a more user friendly aspect to the transmitter configuration. The graphic display allowed us to incorporate multiple language options in the setup menu such as English, Spanish and Chinese. In the incorporation of the graphic display, the electronics were converted to a digital format. This provided a greater signal recognition capability and an ability to include an "onboard oscilloscope" as an aid in troubleshooting tough applications.

The emphasis on simplicity extended itself beyond the use of multiple languages. The Basic Setup menu has been designed with a series of multiple choice questions which, when answered correctly, will configure the transmitter to the installation. The mA Output Setup menu has been expanded to include Loop Test and HART<sup>®</sup> Address capabilities.

Coupled with the development of the MT5000 series was the development of the KCOM<sup>™</sup> software. KCOM<sup>™</sup> is a diagnostic tool which allows the MT5000 to be remotely configured using a computer and HART<sup>®</sup> interface modem. Beyond the Basic Setup parameters, the software will allow the user to view the return signal of the MT5000 on the computer screen. As a trouble shooting tool, a screen shot of the waveform may be taken and sent to the factory for analysis. The KCOM<sup>™</sup> software is free and may be downloaded from our website at [www.abb.com/level](http://www.abb.com/level).

For more information on the MT5000 series including liquid/liquid interface and bulk solids measurement visit our website at [www.abb.com/level](http://www.abb.com/level).

## 2.0 OVERVIEW

### 2.1 Storage and Handling Information

If possible, storage prior to installation should be indoors at ambient temperature, not to exceed the following:

Temperature range: -40 to 150 degrees F.

Humidity: 0 to 100% R.H. non-condensing.

To avoid probe damage:

Do not transport or support the weight of the MT5000 by means of the probe.

Installation of rigid probes and flange mounted transmitters may require the use of lifting equipment.

Avoid sharp bending of cable probes which can result in poor instrument operation.

The lids on the MT5000 housing are sealed with o-rings. To avoid damage to the electronics, both lids should be closed tightly before and after installation.

### 2.2 Ambient Temperature

The MT5000 electronics temperature may not exceed 170°F / 77°C. For higher ambient temperatures due to radiant process heat, a high temperature extension option is required. The coupler process temperature shall not exceed the temperature stated in the datasheet specifications for the given coupler.

### 2.3 Description & Principle of Operation

The MT5000 is a 4-20mA loop powered Smart Level Transmitter, which is microprocessor based and is available with HART® communication. It uses very low power microwave energy to determine the level of the product being measured. In order to obtain optimum performance, it is important to understand the basic principle of operation. The electronics housing is typically fitted with a special adapter “Coupler” serving as a process connection and seal, and holding a solid rod or a cable. The rod or cable “Probe” hangs into the vessel and acts as a wave-guide, i.e. the microwave energy stays concentrated around the probe and along its length, instead of being dispersed in a cone, as it would be if there was no probe.

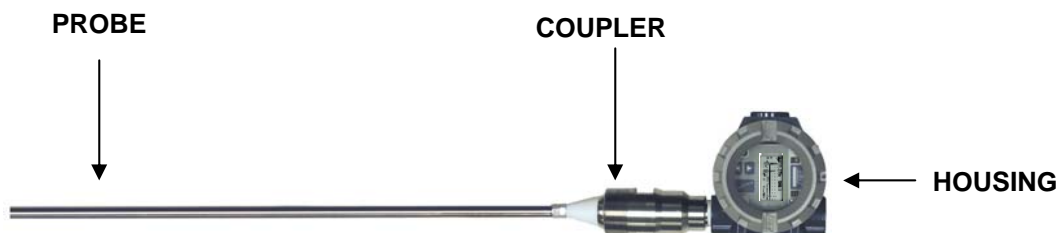

A measurement cycle consists of the following:

1. A very short “pulse” of microwave energy is applied at the coupler, to the Probe.
2. The pulse travels along the length of the probe and when it encounters a discontinuity that is a dielectric constant change, such as the product surface, some of the energy is reflected and travels back towards the coupler.
3. When the reflected energy reaches the coupler, it is sensed by the electronics. By measuring the time elapsed between the initial pulse and the reflected one, the electronics can calculate the product level.
4. Since the microwave energy travels at the speed of light, one complete measurement cycle is made up of several thousands of Pulses. The electronics uses Time Domain Reflectometry (TDR), a sampling technique to reconstruct a waveform duplicating the actual real time signal, but at a much lower speed, so that it can be processed by the microprocessor. This process can be compared to using the stroboscope effect as when observing a piece of machinery turning at high speed with a strobe light.
5. The measurement cycles are made 2 times per second and processed by special filtering techniques, before generating a current output proportional to the level of the product.

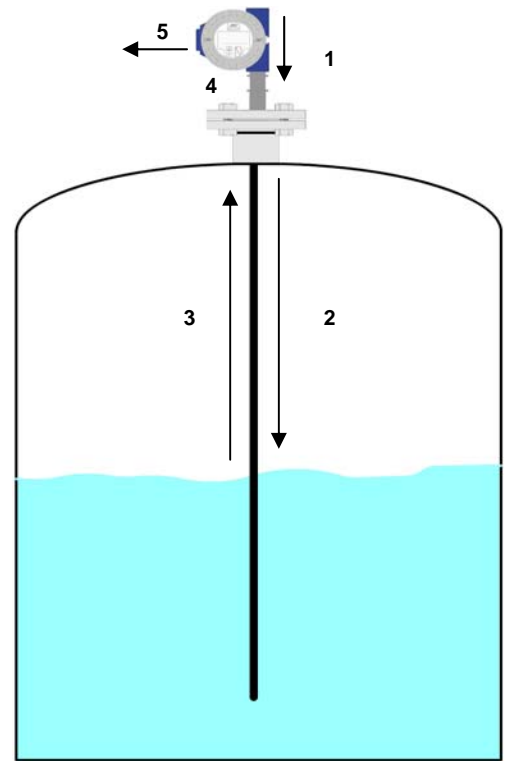

A simplified signal trace as seen on the graphic display (Figure 1) can be divided into three identifiable sections: Coupler Reflection, Signal Reflection and End of Probe Reflection.

The measurement principle using TDR is based on the fact that a dielectric constant discontinuity or geometric change will yield a positive pulse having certain amplitude above the baseline. The greater the dielectric constant difference, the greater the positive amplitude of the return signal. This means that a signal will show up on the baseline if there is a substantial change from a nozzle diameter to an open tank, for example, as signal plot at the process connection. This fact will be taken into account in the configuration of the MT5000 (Consult Basic Setup (Section 4.3) on Commissioning).

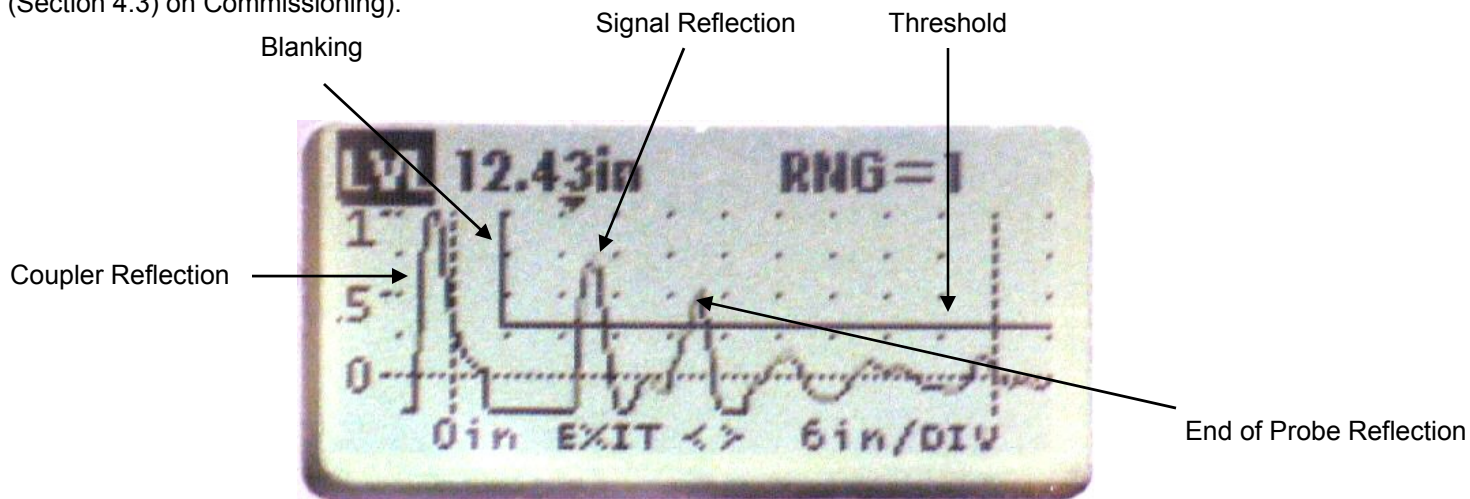

Figure 1

**Note:** Operation is subject to the following two conditions:

1. This device may not cause harmful interference.
2. This device must accept any interference received, including interference that may cause undesired operation.

## 3.0 INSTALLATION

### 3.1 Mechanical Installation

Guidelines and Warnings for MT5000 installation:



**Do not tamper or remove coupler from transmitter housing as this will damage the coupler.**

#### All Installations

1. Do not mount the MT5000 in the product fill stream.
2. To obtain the best return signal from the product level mount the MT5000 coupler directly into the top of the vessel.
3. Do not mount MT5000 single probes using bushings. (Figure 2)
4. Ideally, probes should be mounted in the center of the vessel to provide the maximum measuring range.
5. Avoid internal obstructions such as tubing, ladders or agitators.
6. An MT5000 installed in a nozzle whose height is greater than its width will have an increased non-linear zone at the top of the probe.
7. Cable probes with weights should be allowed to hang under the tension of the weight within the vessel. Shortening of the probe may be required.
8. To avoid excessive movement of the MT5000 probe in an agitated process, or where installation close to the vessel wall is required, secure the bottom end of the probe to the vessel. Probes installed from top of the vessel may require the use of a stilling well.
9. Probes installed in side vessel connections require additional probe support within the nozzle connection.
10. Threaded connections should be installed with thread sealant approved for use by the consumer. Flanged connections should be made using materials (bolts, studs, nuts, and gaskets) and procedures (torque specifications) approved by the consumer.

#### Assembly Instructions for Loose Shipments:

At times, the rigid probe (i.e. P01 or P02) or flexible cable (i.e. P11 or P12) will be shipped as a loose (separate) assembly. In this case, an identification tag will be attached to the probe/cable to identify the serial number/transmitter it is associated with.

1. Locate the top end of the probe/cable that has a threaded FNPT connection.
2. Locate the bottom end of the transmitter coupler that has a threaded MNPT connection.
3. Apply LOCTITE 222MS to the MNPT connection.
4. Fasten the probe/cable hand tight to the MNPT connection and allow this to cure for 15 minutes.
5. Ready for installation.

#### Plastic Tanks, Fiberglass Tanks, and Open Air Installations

1. Single probe units require the use of a metal mounting flange or plate to launch the microwave energy down length of the probe. A minimum 6 inch (150mm) OD, 3/8 inch (10mm) thick plate should be used.
2. A MT5000 installed in a non-metallic vessel or open air environment will be subject to interference from other electromagnetic devices such as radios. Stilling wells may be required to eliminate this interference.

#### Concrete Tanks

1. Tanks constructed of concrete require probe mounting be:
  - 1 ft. / 0.3 m from wall with up to 20 ft. / 6.1 meter measuring length
  - 2 ft. / 0.61 m from wall over 20 ft. / 6.1 meter measuring length
2. Single probe units require the use of a metal mounting flange or plate to launch the microwave energy down length of the

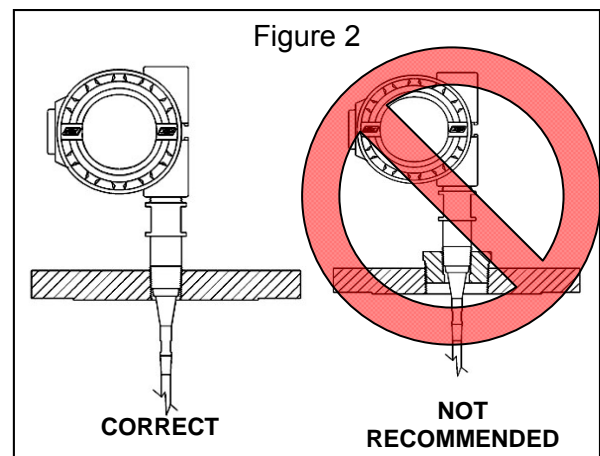

### 3.2 Shortening of Probe

The MT5000 single rod and cable probe can be cut to length prior to installation. If shortening of the probe is necessary, cut the rod or cable to the desired length using a hacksaw.

Shortening of coaxial probes in the field is not recommended.

The centering disc or weight at the end of the probe must be reattached for proper operation. The Probe Length parameter in the Basic Setup menu will need to be adjusted for the new probe length.

### 3.3. Electrical Installation

Electrical connection to the MT5000 should approach the transmitter head from below the conduit opening to provide a drain for moisture. Install conduit to 1/2" NPT port and run 18 gauge twisted, shielded pair to housing. Refer to Section 4 wiring diagram ELE1015 for typical loop wiring diagram and to ELE1014 for instructions applicable to intrinsic safety installation.

Apply loop power to the transmitter as follows:

Terminal Block +	14 VDC minimum to 36 VDC Maximum
Terminal Block -	To control System Input
Ground Screw	GROUND

Note: The "+Meter" and "-Meter" terminals are available to hook up a mA meter to monitor loop current, without breaking the loop.



The housing cover can only be removed when the unit is installed in a non-hazardous area, when installed with intrinsic safety barrier, or when power is removed from the transmitter.

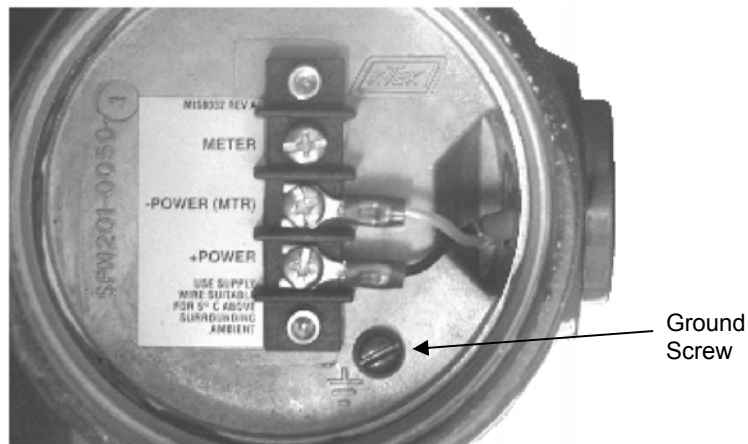

## 4.0 COMMISSIONING

The MT5000 transmitter has been designed with a simple easy to follow setup menu. To make this unit operational, at a minimum, the items in the BASIC SETUP menu must to be entered. If further setup is required, a Quick Calibration may be used or additional menu items will need to be entered.

### 4.1 Display Operation

When power is applied to an MT5000 series transmitter, the display will light up with a title screen which shows the model type and the software revision. (Figure 4) This initial power up cycle will last for 3 seconds and the current output of the transmitter will hold at 4.00 mA.

Figure 4



After the initial power up cycle, the display will change to show the Measured Level and the Current Output. The output will also shift to the current corresponding to the level. (Figure 5)

Figure 5

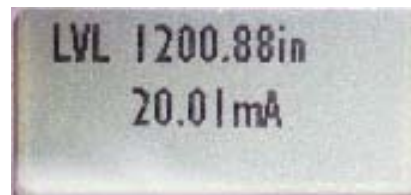

By pushing the UP or Down button, the main display can be scrolled to display the level in terms of a percentage of calibrated range (Figure 6) or in terms of a linearized / strapped measurement. (Figure 7).

Figure 6

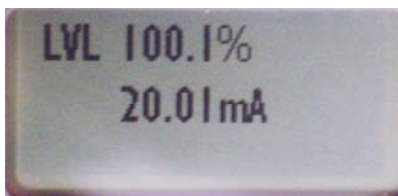
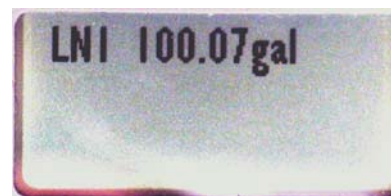

Figure 7





### 4.1.1. JUMPER SETTINGS

The jumper switches are located on the face of the electronics module and can be set up as follows (Figure 8).

#### ALARM (Left Jumper)

Placing the jumper to the lower position causes the output to go to 21.00 mA when there is a loss of signal or transmitter malfunction.

Placing the jumper to the upper position causes the output to go to 3.62 mA when there is a loss of signal or transmitter malfunction.

The alarm output works in conjunction with the ALARM DELAY setting available in the mA OUTPUT menu. The output will go to alarm state only if there is a loss of signal that lasts at least the duration of the alarm delay. The alarm delay default value is two seconds. For instance the output will hold the last measured value if there is a loss of signal lasting less than two seconds and will go into the alarm condition if the loss signal exceeds two seconds.

#### WRITE PROTECT (Right Jumper)

When the jumper is in the lower position the transmitter configuration cannot be changed manually or via HART® communication. (Figure 8).

Placing the jumper in the upper position will allow the configuration parameters to be changed manually or via HART® communication. (Figure 8).

### 4.1.2. PUSHBUTTONS

Three pushbuttons are located on the lower portion of the module faceplate (Figure 8). These buttons will be used to navigate through the setup and configuration menu of the MT5000. Some operations will require the pushbuttons to be used together or held for a period of time to affect a change.

Figure 8

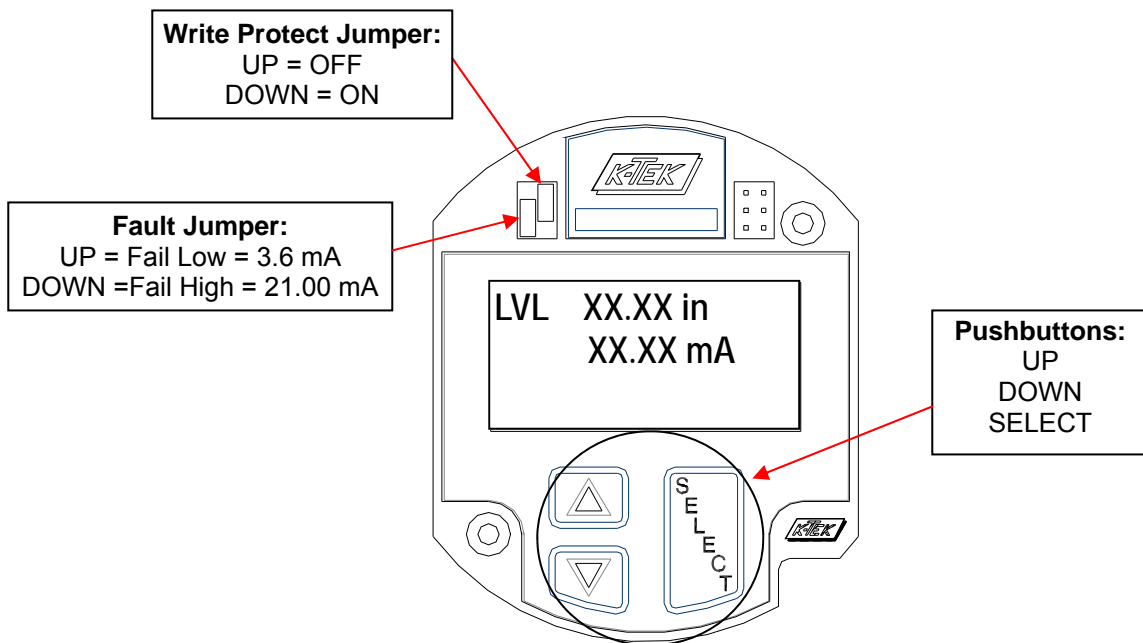

## 4.2 MT5000 Menu Flow Chart

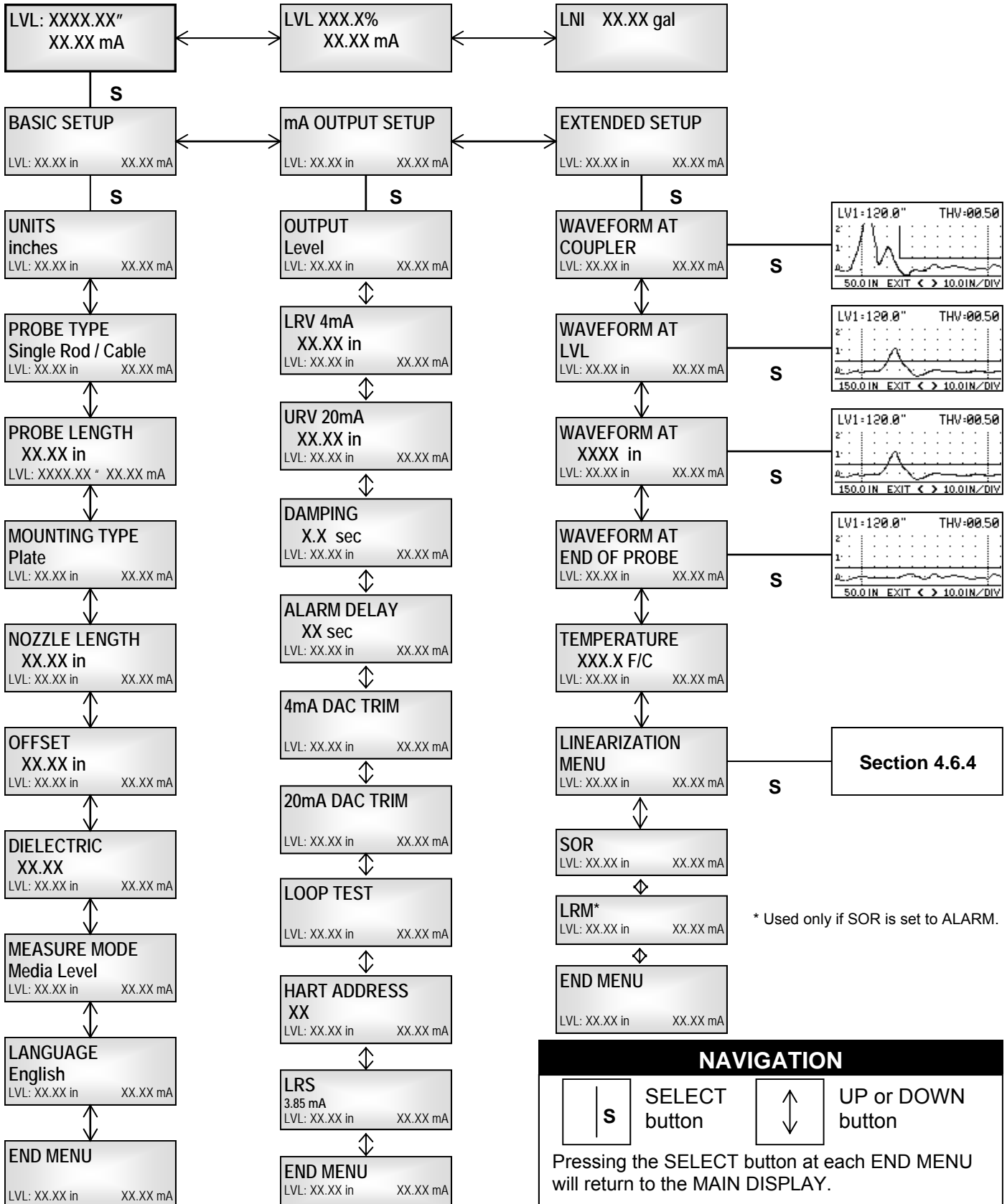

## 4.3 BASIC SETUP

BASIC SETUP is a menu of items that are used to adapt the internal settings of the MT5000 to a particular application. Certain fields are required entry items and will be needed for proper operation of the device. Other entry items are not used for the setup of the transmitter and are listed as optional. At a minimum, the items in the BASIC SETUP menu will need to be entered for the MT5000 to operate. BASIC SETUP menu items include the PROBE TYPE, PROBE LENGTH and MOUNTING TYPE.

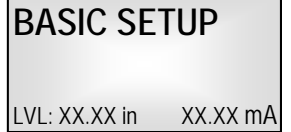

From the main display, press the SELECT button to access the items in the BASIC SETUP menu.

### 4.3.1. UNITS

This function will allow the user to select the UNIT of measure for the process variable of the unit and provide a basis for all of the setup functions. Selectable engineering UNITS include: inches, feet, meters, millimeters and centimeters.



To select the required unit of measure:

1. Press the SELECT button.
2. Scroll UP or DOWN to the desired measurement unit.
3. Press the SELECT button to set the new UNIT.
4. Scroll UP to END MENU.
5. Pressing the SELECT button now will return you to the main screen.

### 4.3.2. PROBE TYPE

This function will help adjust the transmitter setting for the installed configuration. Certain aspects of the transmitter setup will be adjusted to the probe type entered in this location. Selectable probe types include: Single Rod/Cable, Dual Rod/Cable or Coaxial. Select only the type of probe included with the MT5000 transmitter. Failure to set the actual probe type could result in measurement errors.

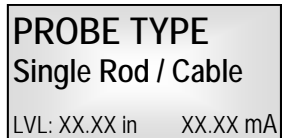

To set the PROBE TYPE:

1. Press and hold the SELECT button for two seconds.
2. Scroll UP or DOWN to the PROBE TYPE as it corresponds to Figure 9 on the following page.
3. Press the SELECT button to set the new PROBE TYPE.
4. Scroll UP to END MENU.
5. Pressing the SELECT button now will return you to the main screen.

**Figure 9**

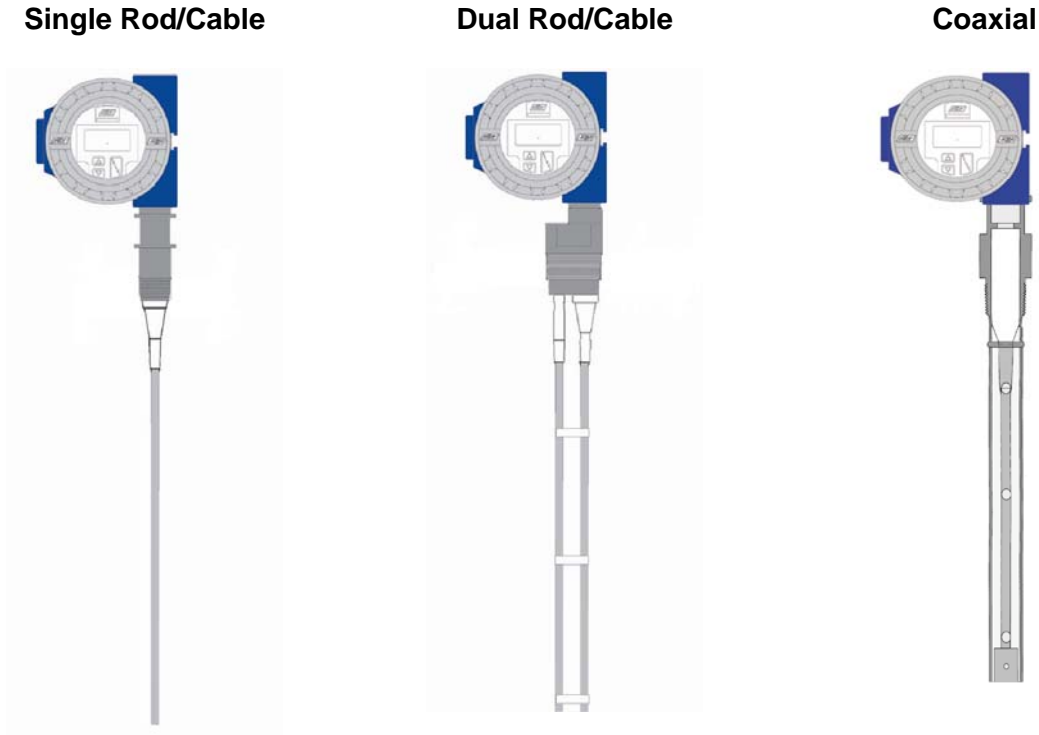

### 4.3.3. PROBE LENGTH

Also described as insertion length, PROBE LENGTH is defined as the measured distance from the first thread of the coupler (or the face of the flange) to the end of the probe. This value must be entered in units that correspond to the UNITS of the process variable.

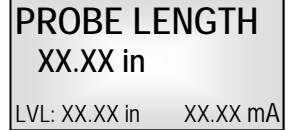

To set the PROBE LENGTH:

1. Press and hold the SELECT button for 2 seconds.
2. Scroll UP or DOWN to set each digit.
3. Press the SELECT button to set the digit and move to the next digit in sequence.
4. After the last digit is set, press the SELECT button to set the new PROBE LENGTH.
5. Scroll UP or DOWN to END MENU.
6. Pressing the SELECT button now will return you to the main screen.

**Figure 10**

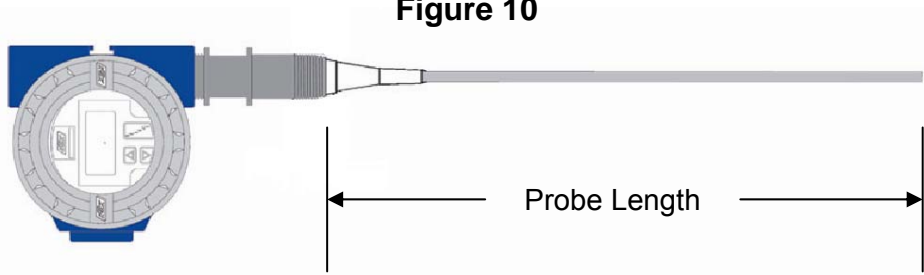

#### 4.3.4. MOUNTING TYPE

Different mounting configurations will affect each probe type in different ways. A coupler mounted on a nozzle whose length is greater than its width will have a reduced signal capacity that must be accounted for by the MT5000. In order to help maximize the range ability of the MT5000, the MOUNTING TYPE corresponding to the installation must be entered. The MOUNTING TYPE should fall into one of the categories listed below. (Figure 11)

<b>MOUNTING TYPE</b>
Plate
LVL: XX.XX in    XX.XX mA

To set the MOUNTING TYPE:

1. Review the installation and determine which class of mounting configuration the unit will be installed in.
2. Press and hold the SELECT button for 2 seconds.
3. Scroll UP or DOWN to the required MOUNTING TYPE.
4. Press the SELECT button to set the new MOUNTING TYPE.
5. Scroll DOWN to END MENU.
6. Pressing the SELECT button now will return you to the main screen

**Figure 11**

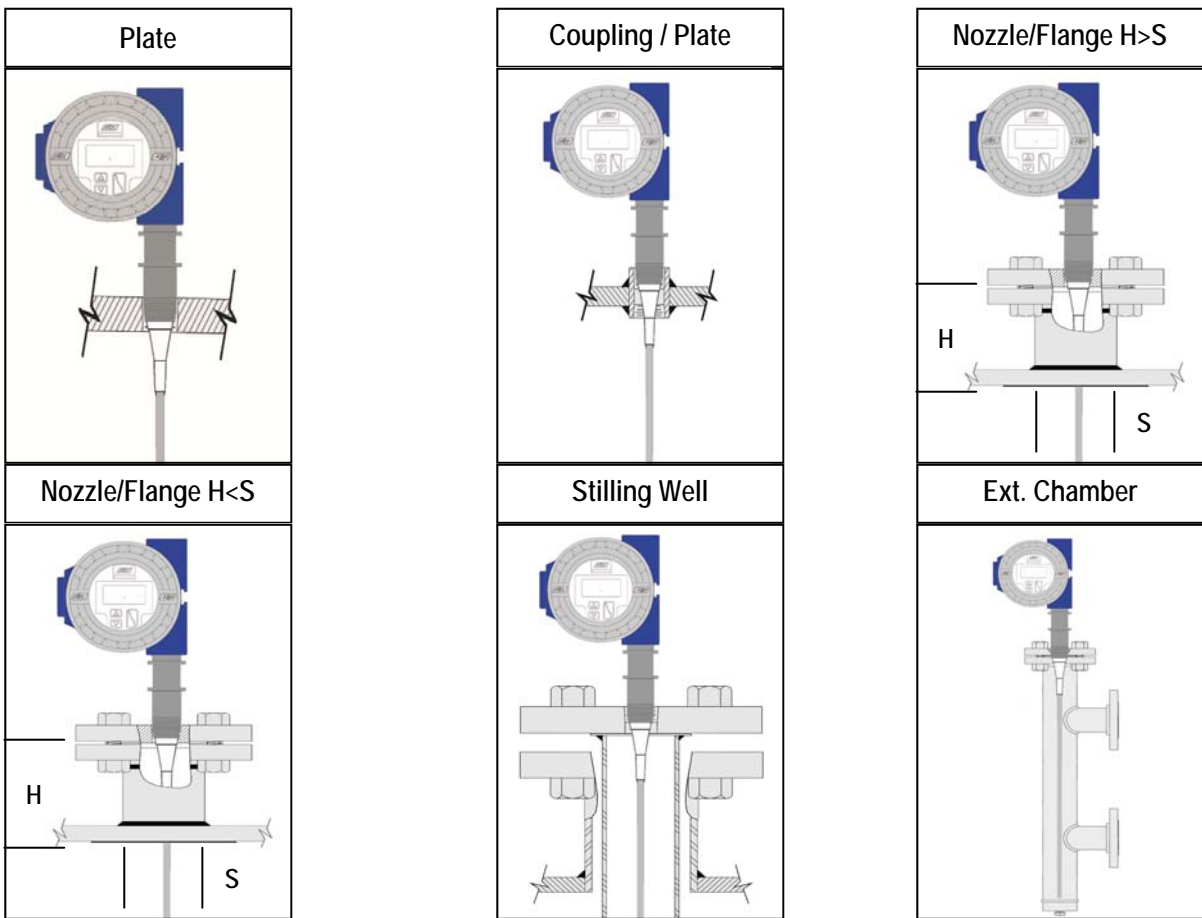

### 4.3.5. NOZZLE LENGTH

In this selection you will enter the length of the mounting nozzle from the face of the coupler to the top of the tank. Transmitters with a Mounting Type of Plate will have a Nozzle Length of 0. This entry will tell the transmitter to ignore any reading within the nozzle area. (Figure 12)

<b>NOZZLE LENGTH</b> XX.XX in LVL: XX.XX in    XX.XX mA
---

To enter the NOZZLE LENGTH:

1. Press and hold the SELECT button for 2 seconds.
2. Scroll UP or DOWN to set each digit.
3. Press the SELECT button to set the digit and move to the next digit in sequence.
4. After the last digit is set, press the SELECT button to set the new NOZZLE LENGTH.
5. Scroll UP or DOWN to END MENU.
6. Pressing the SELECT button now will return you to the main screen.

Figure 12

Nozzle Length

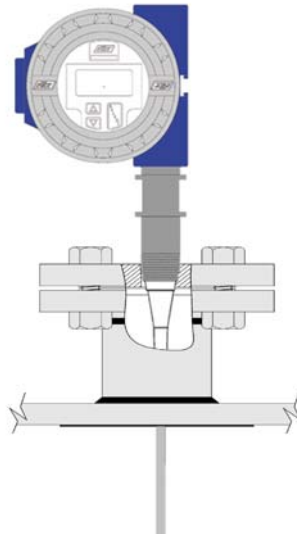

### 4.3.6. OFFSET

Offset is a value in engineering UNITS which may be entered to compensate for an un-measurable area below a probe or to align the measurement of the MT5000 with another device. The value entered in the Offset will be Added to or subtracted from the LVL indication on the main display. (Figure 13)

<b>OFFSET</b> XX.XX in LVL: XX.XX in    XX.XX mA
--

To enter the LVL OFFSET:

1. Press the SELECT button.
2. Scroll UP or DOWN to set each digit.
3. Press the SELECT button to set the digit and move to the next digit in sequence.
4. After the last digit is set, press the SELECT button to set the new LVL OFFSET.
5. Scroll DOWN to END MENU.
6. Pressing the SELECT button now will return you to the main screen.

**Example:**

If the end of the probe, in Figure 13, were 4 inches off the bottom of the tank the Offset would be 4 inches. If the Measured Level were 21 inches after entering the OFFSET, the local indicator would indicate 25 inches (21 +4) and the 4-20 mA<sub>dc</sub> signal would indicate a level of 25 inches.

**Figure 13**

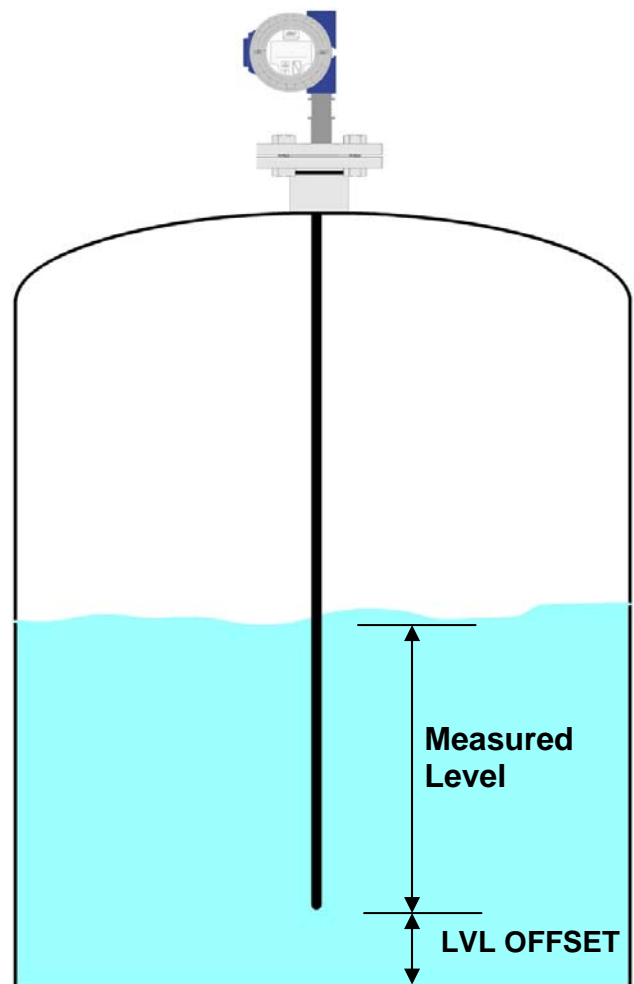

### 4.3.7. DIELECTRIC (OPTIONAL)

The DIELECTRIC setting is an optional entry. It is not used to set or establish any operating parameters within the unit. It will not be necessary to know the exact dielectric constant of the process or to enter a valid value in this setting.

To enter the DIELECTRIC:

1. Press and hold the SELECT button.
2. Scroll UP or DOWN to set each digit.
3. Press the SELECT button to set the digit and move to the next digit in sequence.
4. After the last digit is set, press the SELECT button to set the DIELECTRIC.
5. Scroll UP or DOWN to END MENU.
6. Pressing the SELECT button now will return you to the main display.



### 4.3.8. MEASURE MODE

The MT5000 can be used to measure Media Level or Ullage. Media Level refers to a Level Measurement from the end of the probe to the surface of the liquid level that is measuring the amount of liquid in the tank. Ullage refers to a Level Measurement from the face of the coupler to the surface of the liquid that is measuring the amount of vapor space in the tank. From the factory the MEASURE MODE will be Media Level.

To select the MEASURE MODE:

1. Press and hold the SELECT button for 2 seconds.
2. Scroll UP or DOWN to change the MEASURE MODE between Media Level and Ullage.
3. Press the SELECT button.
4. Scroll DOWN to END MENU.
5. Pressing the SELECT button now will return you to the main display.

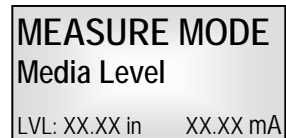
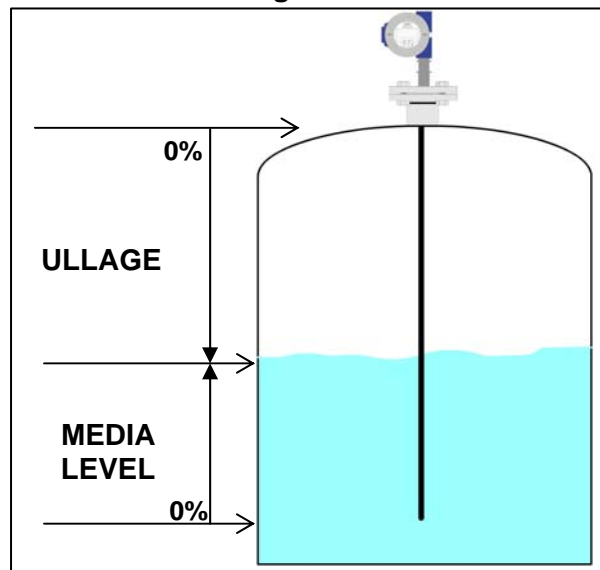

Figure 14





### 4.3.9. LANGUAGE

The MT5000 has been equipped with several different operating languages to assist in the setup of the unit. When a specific language is selected, the titles of the menu items will be translated. Abbreviations specific to the MT5000 will remain unchanged as icons regardless of language selection.



Available LANGUAGES include:

- English
- French
- Spanish
- Portuguese
- Italian
- Russian
- Chinese (Mandarin)

To change the menu LANGUAGE:

1. Press the SELECT button.
2. Scroll UP or DOWN to find the new LANGUAGE.
3. Press the SELECT button to set the new LANGUAGE.
4. Scroll DOWN to END MENU.
5. Pressing the SELECT button now will return you to the main screen.

## 4.4 QUICK CALIBRATION

### Note to User

After the BASIC SETUP menu items have been entered, the MT5000 will be operational. The 4 milliamp output point of the transmitter will be set at the 0 measurement point and the 20 milliamp point will be set at the highest measured value. The location of the 4 and 20 milliamp points will be determined by the Measurement Mode. If the probe is measuring the level of the process accurately but is not returning the desired milliamp output, it is possible to quickly recalibrate the MT5000 based on the measured level from the transmitter.

### Procedure

#### Setting the 4 milliamp output.

1. Raise or lower the liquid level to the desired 4 milliamp point.
2. Press the UP and DOWN buttons on the MT5000 at the same time.
3. Press the DOWN button to set the 4 milliamp point.

#### Setting the 20 milliamp output.

1. Raise or lower the liquid level to the desired 20 milliamp point.
2. Press the UP and DOWN buttons on the MT5000 at the same time.
3. Press the UP button to set the 20 milliamp point.

The MT5000 will now be fully operational. If a further detailed setup is required you may proceed to the mA OUTPUT menu, or the Extended Setup menu. If the output of the MT5000 is required to match that of another device, the following alternate procedure may be used.

#### Setting the 4 milliamp output.

1. Raise or lower the liquid level to the 4 milliamp point of the primary transmitter.
2. Press the UP and DOWN buttons on the MT5000 at the same time.
3. Press the DOWN button to set the 4 milliamp point.

#### Setting the 20 milliamp output.

1. Raise or lower the liquid level to the 20 milliamp point of the primary transmitter .
2. Press the UP and DOWN buttons on the MT5000 at the same time.
3. Press the UP button to set the 20 milliamp point.

## 4.5 mA OUTPUT SETUP

The mA OUTPUT SETUP is a menu of items used to control the output signal from the MT5000. In this menu you will find entries for the 4mA point, 20mA point and Damping along with other output related items.

To access the items in the mA OUTPUT SETUP menu from the main display:

1. Press the SELECT button.
2. Scroll DOWN to mA OUTPUT SETUP
3. Press the SELECT button.

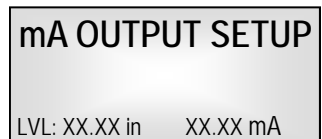

### 4.5.1. OUTPUT

OUTPUT is a function which allows the user to determine which variable the mA OUTPUT of the MT5000 will be based upon. Selections for OUTPUT are Level and LIN Level. Level is the actual linear measurement the MT5000 is interpreting from its configuration. LIN Level is the measurement of the MT5000 as it is filtered through the LINEARIZATION TABLE (Section 4.6.4.)

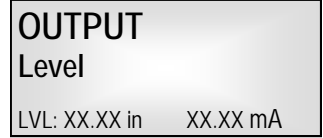

To access the items in the mA OUTPUT SETUP menu from the main display:

1. Press and hold the SELECT button for 2 seconds.
2. Scroll UP or DOWN to the desired OUTPUT variable.
3. Press the SELECT button to set the new OUTPUT.
4. Scroll UP to END MENU.
5. Pressing the SELECT button now will return you to the main screen.

### 4.5.2. LRV 4mA

LRV 4mA is a value in engineering UNITS which determines at which measured value the MT5000 will generate a mA OUTPUT of 4.00mA. Traditionally this is known as the zero point. From the factory the LRV 4mA will be set to 0.00 inches.

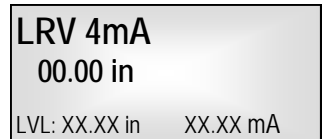

To enter the LRV 4mA:

1. Press the SELECT button.
2. Scroll UP or DOWN to select each digit.
3. Press the SELECT button to set the digit and move to the next digit in sequence.
4. After the last digit is set, press the SELECT button to set the new LRV 4mA.
5. Scroll UP to END MENU.
6. Pressing the SELECT button now will return you to the main screen.

### 4.5.3. URV 20mA

URV 20mA is a value in engineering UNITS which determines at which measured value the MT5000 will generate a mA OUTPUT of 20.00mA. Traditionally, this is known as the span point. From the factory the URV 20mA will be set to the PROBE LENGTH.

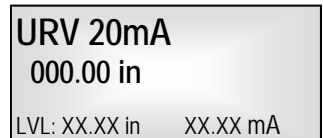

To enter the URV 20mA:

1. Press the SELECT button.
2. Scroll UP or DOWN to select each digit.
3. Press the SELECT button to set the digit and move to the next digit in sequence.
4. After the last digit is set, press the SELECT button to set the new URV 20mA.
5. Scroll UP to END MENU.
6. Pressing the SELECT button now will return you to the main screen.

**Figure 15**

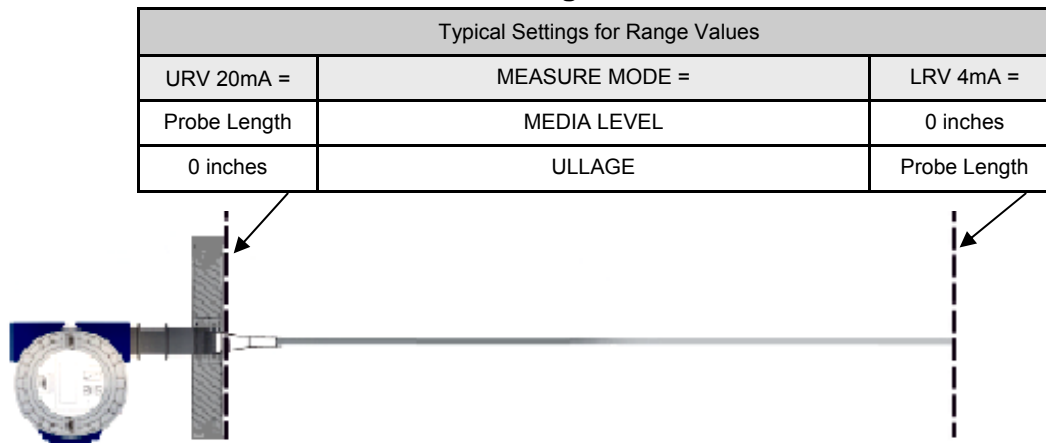

#### 4.5.4. DAMPING

DAMPING is a setting designed to delay the mA OUTPUT response to a change in measured level. It is a value set in seconds at .5 second intervals. If the process is agitated or splashing of the liquid is possible, a higher DAMPING value may be required. If the process changes rapidly, a lower DAMPING value may be needed to increase the response time to a level change. The highest DAMPING allowable is 36 seconds.

<b>DAMPING</b>
0.5 sec
LVL: XX.XX in    XX.XX mA

To change the DAMPING:

1. Press the SELECT button.
2. Scroll UP or DOWN to select each digit.
3. Press the SELECT button to set the digit and move to the next digit in sequence.  
(The last digit will scroll between .0 and .5)
4. After the last digit is set, press the SELECT button to set the new DAMPING.
5. Scroll UP or DOWN to END MENU.
6. Pressing the SELECT button now will return you to the main screen.

#### 4.5.5. ALARM DELAY

If the MT5000 does not pick up a return signal crossing the threshold it will return an ALARM signal (Section 4.1.1) In an application where the surface of the product may be subject to a change in physical state (such as flashing,) the return signal from the product will appear and disappear as the product boils. To prevent the mA OUTPUT from spiking to ALARM in these conditions, an ALARM DELAY may be set. This delay time will allow the MT5000 to hold the last good value it received for a given time before returning an alarm indication. From the factory the ALARM DELAY will be set to 2 seconds.

<b>ALARM DELAY</b>
2 sec
LVL: XX.XX in    XX.XX mA

To enter the ALARM DELAY:

1. Press the SELECT button.
2. Scroll UP or DOWN to select each digit.
3. Press the SELECT button to set the digit and move to the next digit in sequence.
4. After the last digit is set, press the SELECT button to set the new ALARM DELAY.
5. Scroll DOWN to END MENU.
6. Pressing the SELECT button now will return you to the main screen.

#### 4.5.6. DAC TRIM

The MT5000 is designed as a 2 wire loop powered device. It will generate a mA OUTPUT over a range of 3.61 to 21.00 mA. When an MT5000 is calibrated at the factory, the output of the unit will be set to correspond to a calibrated multi-meter. The exact output is set using the DAC TRIM function. When an MT5000 is installed and wired, the field wiring and other loop components may affect the mA OUTPUT that is received at the point of control. The DAC TRIM will be used to compensate for the loop components and allow the point of control to receive a true 4 and 20 mA.

To adjust either the 4 or 20 mA DAC TRIM:

1. A means of measuring the current output must be established in the control loop.
2. Scroll to the desired function.
3. Press and hold the SELECT button for 2 seconds. (the output will change to what the transmitter interprets as 4 or 20 mA.)
4. Using the SELECT, UP and DOWN buttons to enter the measured current value.
5. Press the SELECT button to set each digit and move to the next digit in sequence.
6. After the last digit is set, the mA OUTPUT will adjust to exactly 4 or 20 mA.
7. Scroll DOWN to END MENU.
8. Pressing the SELECT button now will return you to the main screen.

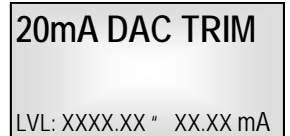

#### 4.5.7. LOOP TEST

LOOP TEST is a function designed to simulate transmitter output at various levels and confirm readings from a separate location. The LOOP TEST may be performed at any mA OUTPUT between 3.61 and 21.00.

To perform a LOOP TEST:

1. Press and hold the SELECT button for 2 seconds.
2. Scroll UP or DOWN to select each digit for the desired mA OUTPUT.
3. Press the SELECT button to set the digit and move to the next digit in sequence.
4. After the last digit is set the mA OUTPUT will change to the desired level. (Another mA OUTPUT may be selected by repeating steps 1 through 4.)
5. Scroll DOWN to END MENU. (The mA OUTPUT will return to normal operation after pushing the DOWN arrow)
6. Pressing the SELECT button now will return you to the main screen.



#### 4.5.8. HART ADDRESS

HART ADDRESS is a selection which will allow the user to assign a numerical address to the MT5000. Setting the address of the unit will allow the MT5000 to be polled when installed in a string of transmitters. The HART ADDRESS may be set to any number from 0 to 15. As a default value, the MT5000 is set with an address of 0. This allows the MT5000 to operate normally. If an address other than 0 is set in the MT5000, the mA output of the transmitter will hold at 4.00mA and the measured level will continue to operate as normal.

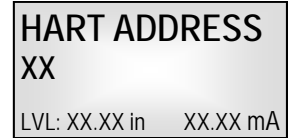

To enter a HART ADDRESS:

1. Press and hold the SELECT button for 2 seconds.
2. Scroll UP or DOWN to set each digit.
3. Press the SELECT button to set the digit and move to the next digit in sequence.
4. After the last digit is set, press the SELECT button to set the new PROBE LENGTH.
5. Scroll UP to END MENU.
6. Pressing the SELECT button now will return you to the main screen.

**NOTE:** For more information on HART<sup>®</sup> communications and addressing visit [www.hartcomm.org](http://www.hartcomm.org).

#### 4.5.9. LRS (HART VERSION ONLY)

Low Range Saturation is the lowest current output that the transmitter can attain in normal operation (not in alarm condition), regardless of the actual measurement value. The LRS limit has no effect on the “Fail Low” alarm current (3.60mA if selected) with the Fail Hi/Lo jumper position on the face of the module. Should the transmitter lose its echo, the transmitter will immediately enter its low alarm state (no damping effect) of 3.60mA. LRS has two selections:

- 3.85 sets 3.85mA as the low limit for the mA signal. As the level decreases below the LRV, the output current will change proportionally, down to the limit.
- 4.0 sets 4.0mA as the low current limit from the transmitter, preventing a “negative” level in the control system.

## 4.6 EXTENDED SETUP

EXTENDED SETUP is a menu containing features designed to fine tune the operation of the MT5000. This menu contains WAVEFORM options which allow access to a graphic representation of the return signal and a LINEARIZATION MENU.

EXTENDED SETUP

LVL: XX.XX in    XX.XX mA

To access the items in the EXTENDED SETUP menu from the main display:

1. Press the SELECT button.
2. Scroll DOWN to EXTENDED SETUP.
3. Press the SELECT button.

### 4.6.1. WAVEFORM DISPLAY

The first four menu options in the EXTENDED SETUP, will allow access to a graphic display of the return signal from the sensor of the MT5000. Each of these WAVEFORM screens has the same configuration and will allow access to the same functions. Figure 4.6.1. outlines the features of the WAVEFORM screens.

Figure 16

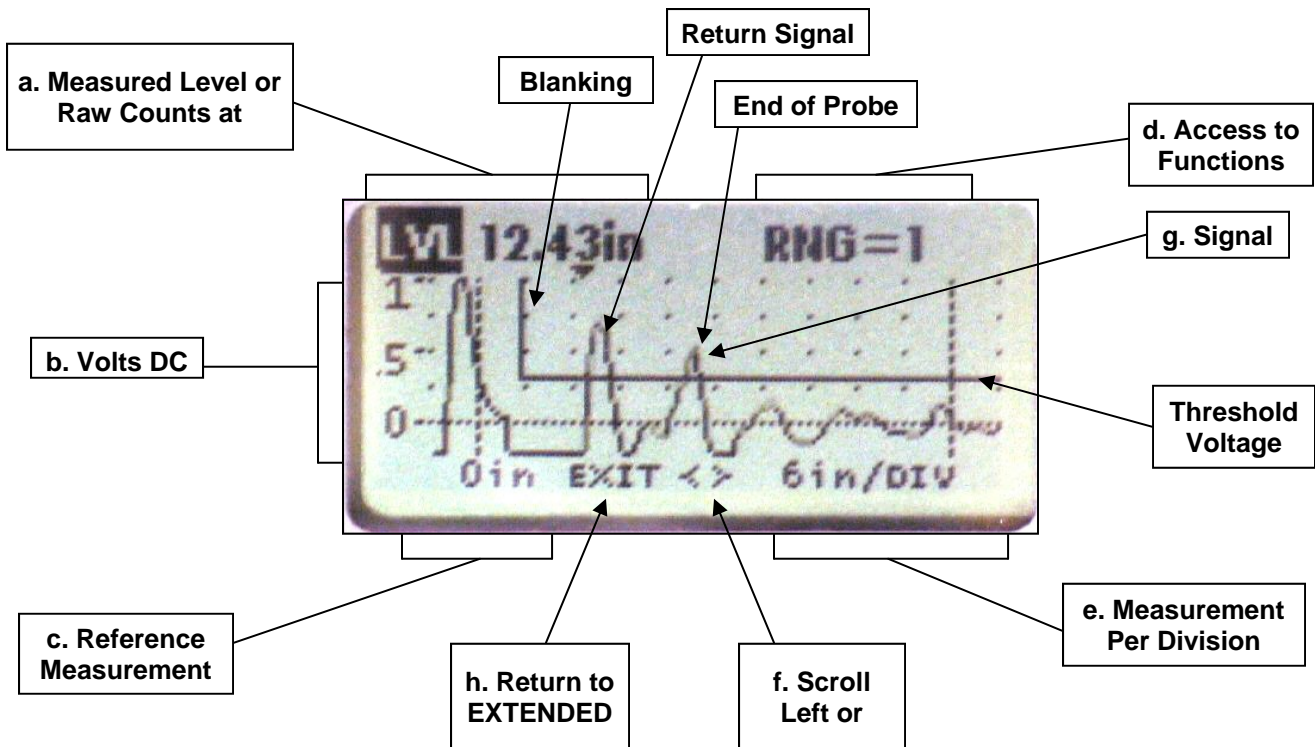

After entering each of the WAVEFORM screens you may navigate through them by using the UP and DOWN buttons. To make adjustment to an item, highlight the item and press the SELECT button. Certain functions will require holding the SELECT button for 2 seconds to enter the field. Functions on the WAVEFORM screen will only affect the appearance of the graphic display not the operation of the MT5000.

- a. **Measured Level / Raw Counts** - Displays the Media Level or Ullage as determined by the transmitter. Pressing the SELECT button here will scroll this portion of the display between the Measured Level and the Raw Counts at the Measured Level.
- b. **Volts DC** - Scaling of the graphic display from 0 to 1 VDC. The return signal will rise up from 0 volts towards 1 volt.
- c. **Reference Measurement** - The dotted vertical line to the left of the display provides a reference measurement for the WAVEFORM. The measured value at this dotted line will be displayed in the bottom left hand portion of the screen and provide a starting point for determining the position of the signal. Regardless of the MEASURE MODE, reference measurements are made from the face of the coupler or the mounting flange.
- d. **Access to Functions** - This section will allow entry to separate menu items to adjust the appearance of the signal and the signal detection capabilities. Some of these settings will be determined by the values entered in the BASIC SETUP menu and adjustments made to these settings are to be made only when absolutely necessary. (Section 4.5.2.)
- e. **Measurement per Division** - The WAVEFORM display will be divided into horizontal sections or divisions. The separations in the divisions will remain constant on the display. Variation in the appearance of the signal will be based on the Measurement per Division. The available measurements per division will be dependant upon the UNITS set in the BASIC SETUP menu. To adjust the Measurement per Division, scroll down to highlight the setting and press the SELECT button.

Table 1			
UNITS	Available Measurement per Division		
inches	6 in / div	12 in / div	24 in / div
feet	.5 ft / div	1 ft / div	2 ft / div
millimeters	100 mm / div	250 mm / div	500 mm / div
centimeters	10 cm / div	25 cm / div	50 cm / div
meters	.1 m / div	.25 m / div	.5 m / div

- f. **Scroll Left or Right** - This function will allow the Reference Measurement to be shifted based on the Measurement per Division giving access to the full WAVEFORM. Shifting the Reference will not affect the operation of the MT5000. Pressing the SELECT button with < highlighted will shift the reference 5 divisions to the left. Pressing the SELECT button with > highlighted will shift the reference 5 divisions to the right. The displayed reference may not be shifted to a value less than 0 measurement.
- g. **Signal** - The actual return signal from the antenna of the MT5000. The signal from the measured level will appear as a rising wave that moves up from 0 volts toward 1 volt then falls back down towards 0. This signal must cross the Threshold Voltage to the right of the blanking to be registered as a measurement by the MT5000.
- h. **Return to EXTENDED SETUP** - Pressing the SELECT button while EXIT is highlighted will back out of the WAVEFORM screen and revert back to the EXTENDED SETUP menu.



## 4.6.2. FUNCTIONS

Adjustments to the settings which control the shape of the signal and what part of the signal is accepted as the measurement may be accessed through the WAVEFORM screens. By highlighting the function in the top right corner of the WAVEFORM screen and pressing the SELECT button, you can scroll through each of these functions. To adjust a certain function, when the function appears, press and hold the SELECT button for 2 seconds. The WAVEFORM screen will change to a field entry screen which corresponds to the function.

### Functions Available from the WAVEFORM screen:

#### 1. LTV = Threshold (in DC Volts)

The Threshold voltage provides a method of signal detection along the waveform. Digitally set from 0 to 2 volts, the return signal from the process must cross this barrier to be detected as a signal. The MT5000 is designed to detect the first pulse crossing the Threshold. The Threshold may need to be raised to avoid baseline interference or lowered to detect the correct pulse.

#### 2. BLK = Blanking (in terms of UNITS)

Blanking is a measured area which the MT5000 will be set to ignore. This will be set based on the NOZZLE LENGTH from the BASIC SETUP menu. It may be necessary to extend the Blanking further past the nozzle to ignore reflections from the top portion of the probe. Blanking is set in terms of UNITS. To adjust the Blanking enter the distance from the Reference Measurement to be ignored.

#### 3. GAIN = Signal Amplification (1 thru 99)

GAIN is a factory set function designed to adjust the return pulse to the best possible signal to noise ratio. The GAIN setting will be optimized by the MT5000 based on the entries from the BASIC SETUP menu. Increasing the GAIN setting will amplify the noise as well as the return pulse. Lowering the GAIN setting will decrease the return pulse as well as the noise.

#### 4. SHAPE = 1 or 2

The SHAPE function will be set based on the mounting configuration. Like the GAIN function it is designed to create the best signal to noise ratio from the return pulse. The SHAPE setting will determine how the signal is amplified.

#### 5. RNG = 1 or 2

The RANGE setting is determined by the PROBE LENGTH. Probes shorter than 100 feet will be set to RANGE 1. Probes from 100 to 200 feet will be set to RANGE 2. Changing the RANGE setting will erase all factory trim settings and calibration values. Changing the RANGE setting is not recommended unless a commitment to changing the physical probe length has been made.

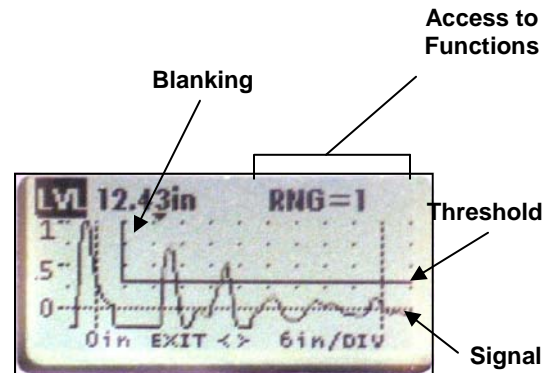

THRESHOLD  
X.XX  
LVL: XX.XX in    XX.XX mA

BLANKING  
XX.XX inches  
LVL: XX.XX in    XX.XX mA

GAIN  
XX  
LVL: XX.XX in    XX.XX mA

SHAPE  
1  
LVL: XX.XX in    XX.XX mA

RANGE  
1  
LVL: XX.XX in    XX.XX mA

Note: After setting the value of each function, pressing the SELECT button will return you to the WAVEFORM screen.

### 4.6.3. TEMPERATURE

The TEMPERATURE indication in the EXTENDED SETUP menu is an indication of temperature internal to the electronics module. It is not used for temperature compensation. The TEMPERATURE will toggle between Celsius and Fahrenheit.

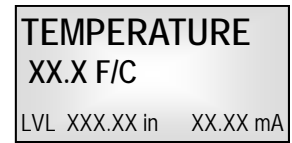

#### 4.6.4. LINEARIZATION MENU

The LINEARIZATION function of the MT5000 is a multi-purpose tool designed to enhance the operating capabilities of the MT5000 transmitter. The format of the LINEARIZATION TABLE allows a set of values to be assigned to measured level points along the PROBE LENGTH. The points in the table can be assigned exact measured values to linearize the measured level for increased accuracy at the top and bottom of the probe, assigned volume points for tank strapping, or assigned flow rates for measurement of flow in an open channel.

##### LINEARIZATION MENU items:

###### 1. LIN UNITS

Allows the selection of the desired output UNITS based on the values of the linearization table. LIN UNITS include measurement selections such as meters, volume selections such as gallons, and flow selections such as liters/hour. (Table 2)

###### 2. LIN MINIMUM

The value assigned to the lowest measurable point along the PROBE LENGTH. Typically this will be set to 0, although it is not required.

###### 3. LIN MAXIMUM

The value assigned to the highest measurable point along the PROBE LENGTH. This value will be greater than the largest point in the Linearization Table.

###### 4. LIN MODE

This will determine how the values in the table will be assigned. Manual Mode allows the entry of the values along with the respective measured level. Automatic requires the level of the product to be at the measured level when the respective value is set.

###### 5. LINEARIZATION TABLE

The set of parameters used to collate Measured Level and a user selected set of values for those Measured Levels. Table points will be entered based on the LIN MODE. Table points must be entered from smallest value to largest value from point 01 to point 20. In Manual Mode, the table will ask for Output Point 01-20 then ask for the corresponding Input Point 01-20. The Output Point is the desired reading. The Input Point is the Measured Level. In Automatic Mode, the table will only ask for the Output Point 01-20. The corresponding Input Point will be gained by setting the level to the correct location along the PROBE LENGTH.

```
LIN OUTPUT
Level
LVL XX.XX in  XX.XX mA
```

```
LIN UNITS
inches
LVL XX.XX in  XX.XX mA
```

```
LIN MINIMUM
XX.XX
LVL XX.XX in  XX.XX mA
```

```
LIN MAXIMUM
XXX.XX
LVL XX.XX in  XX.XX mA
```

```
LIN MODE
Manual
LVL XX.XX in  XX.XX mA
```

```
LINEARIZATION
TABLE
LVL XX.XX in  XX.XX mA
```

Changing the UNITS in the BASIC SETUP menu will automatically change the UNITS of the Input Points. Changing the LIN MAXIMUM after table points are set will cause the table points to change based on the percentage change of the LIN MAXIMUM.

**Table 2**

Linearization Output Units					
Level	Volume		Flow		
inches	gallons	cubic yards	cubic ft/sec	cubic meters/sec	liters/sec
feet	liters	cubic feet	cubic ft/min	cubic meters/min	liters/min
millimeters	imperial gallons	cubic inches	cubic ft/hr	cubic meters/hr	liters/hr
centimeters	cubic meters	liquid barrels	cubic ft/day	cubic meters/day	million liters/day
meters	barrels	hectoliters	gallons/sec	barrels/sec	imperial gallons/sec
percent (%)	bushels		gallon/min	barrels/min	imperial gallons/min
			gallons/hr	barrels/hr	imperial gallons/hr
			gallons/day	barrels/day	imperial gallons/day
			million gallons/day		

**LINEARIZATION for LEVEL**

Due to the nature of the microwave energy and the physics involved in the measurement of the MT5000, measurements return signals on the top and bottom end of the probe may be non-linear. The degree of non-linearity will depend upon the dielectric of the material being measured, the configuration of the probe, and the proximity of the material to the ends of the probe. A typical table setup for measurement linearity will only contain a few Output Points. Points not used will be left set to 0.00. Below is an example of Linearization set up for Measurement Linearity.

SETTINGS			
LIN OUTPUT Level	LINEARIZATION TABLE		
LIN UNITS	MEASURED LEVEL	OUTPUT POINT	
inches			
LIN MINIMUM 00.00	0.25"	01	1.00"
	1.50"	02	2.00"
LIN MAXIMUM 48.00	2.75"	03	3.00"
	3.88"	04	4.00"
LIN MODE Auto	NOT USED	05 thru 16	0.00"
PROBE LENGTH 51.00	43.88"	17	44.00"
	44.75"	18	45.00"
NOZZLE HEIGHT 3.00 inches	45.50"	19	46.00"
	46.25"	20	47.00"

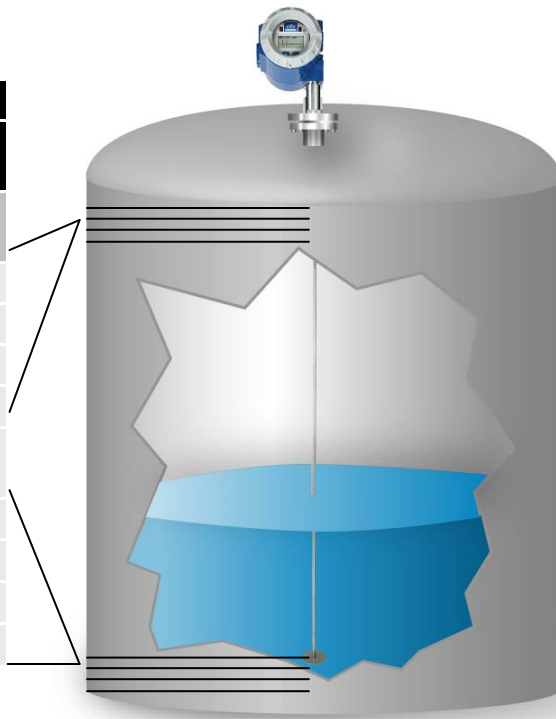

## LINEARIZATION for VOLUME

The MT5000 is designed to measure level in a linear fashion over the length of the probe. If the transmitter is installed in a straight sided tank, the volume of the tank may be calculated by knowing the amount of product per unit of measurement. However, if the MT5000 is installed in a tank with round sides, like a sphere or bullet tank, the amount of product per unit measurement will change from one point to the next. For this reason the Linearization has been designed with the flexibility to accept a strapping table as an output. With the LIN MODE set to Manual, a 20 point strapping table may be entered into the Linearization Table to allow the MT5000 to display a volume measurement. If a strapping table is not available for the tank, with the LIN MODE set to Automatic, a given amount of liquid may be added to the tank and the Output Points set based on that given amount. Below is an example of a Linearization setup for Volume using the Manual Mode.

SETTINGS			
LIN OUTPUT Volume	LINEARIZATION TABLE		
LIN UNITS gallons		INPUT POINT	OUTPUT POINT
	01	5.00"	115.86
	02	7.00"	188.53
LIN MINIMUM 00.00	03	9.00"	270.37
	04	11.00"	361.70
	05	13.00"	456.80
	06	15.00"	556.56
LIN MAXIMUM 2010.00	07	17.00"	662.40
	08	19.00"	818.75
	09	21.00"	876.49
	10	23.00"	988.07
LIN MODE Manual	11	25.00"	1097.32
	12	27.00"	1206.04
	13	30.00"	1368.89
	14	32.00"	1472.69
PROBE LENGTH 98.00 in	15	34.00"	1575.34
	16	36.00"	1671.05
	17	38.00"	1761.10
	18	40.00"	1845.96
NOZZLE HIEGHT 3.00 inches	19	42.00"	1919.85
	20	43.00"	1952.56

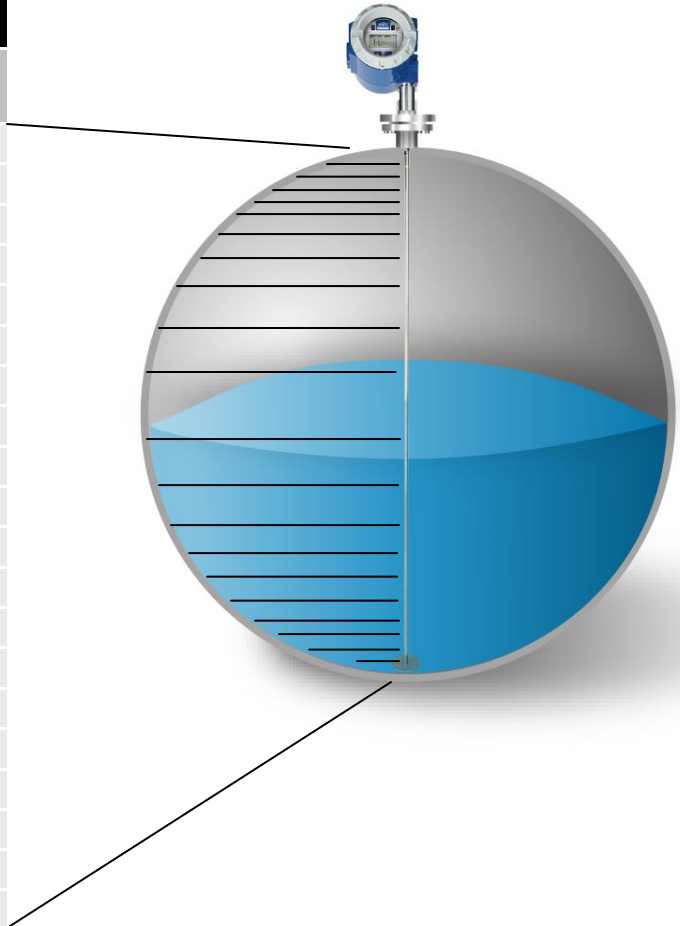

## LINEARIZATION for FLOW

Fluid flow in a flume or open channel will present some of the same characteristics as a level in a tank. If you examine a cross section of a liquid flowing at a particular rate through a channel, it will rise to a certain level in that channel. As the flow increases, the level in the cross section of channel will rise. Knowing the aspects of the channel, we can create a correlation between the measured level of the fluid and the rate of flow through the channel.

Due to the method of operation of the MT5000 and the physics of flow, there are specific mounting requirements when using a Guided Wave Radar transmitter in a flow application.

1. A rigid probe must be used and it must be secured to the bottom of the flow channel.
2. A single rod probe design will require the use of a metal launch plate mounted to the MT5000 coupler.
3. The MT5000 probe and transmitter must be mounted 3 times the head height upstream from the end of the channel or from the flow change.

Below is a typical Linearization setup for channel flow.

SETTINGS	LINEARIZATION TABLE		
LIN OUTPUT Flow			
LIN UNITS gallons/min		Input Point	OUTPUT POINT
LIN MINIMUM 00.00	01	0.50"	10.00
	03	1.00"	20.00
LIN MAXIMUM 80.00	05	2.00"	30.00
	07	3.00"	40.00
LIN MODE Manual	09	4.00"	50.00
	11	5.00"	60.00
PROBE LENGTH 24.00	Points 02,04,06,08,10 and 12-20 are not used		

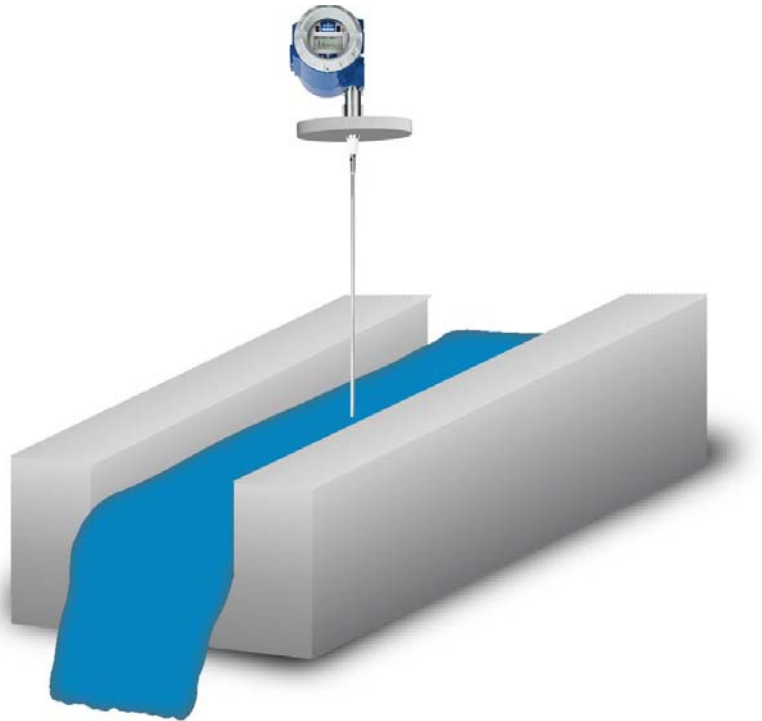

## User Functions

At the end of the Output / Input Points there are three User Functions for the Linearization Table. These Functions are here to assist the user with the Linearization Table values.

<b>BACK UP</b> Table LVL XX.XX in XX.XX mA
--

1. **BACK UP Table** - Selecting this Function will store all of the values in the Linearization Table to a Back Up file in the Eprom of the MT5000.
2. **RELOAD Table** - Selecting this Function will reinstall the values of a Linearization Table that have been stored in the Back Up file of the MT5000.
3. **CLEAR Table** - Selecting this Function will completely erase all values from the Linearization Table.

<b>RELOAD</b> Table LVL XX.XX in XX.XX mA
---

These functions will only affect the Linearization Table values. They will not affect any other settings of the MT5000.

<b>CLEAR</b> Table LVL XX.XX in XX.XX mA
--

### 4.6.5. SOR (HART VERSION ONLY)

Signal Out of Range: SOR has two selections – SATURATION = Saturation; ALARM = Alarm. This function prevents the abrupt mA output change that is common in applications of low dielectric constant fluids in EC chambers. To take advantage of this programming, the module's Failure Alarm jumper should be set HIGH, and SOR Set to ALARM.

Description: SATURATION (normal operation) and ALARM selections are described below.

- A. **SATURATION** – (Existing transmitter normal operation with a low D.C. fluid): When the chamber level exceeds the URV, the output will continue to track the level until the output saturates at 20.56mA. Should the level continue to increase to the point that the level echo is lost, the next echo that the module immediately recognizes is the centering disc at the end of the antenna. Since the centering disc echo is being detected through the low DC fluid, it appears significantly below the actual distance and the output drives to 3.85mA (saturated output) causing significant control problems. This situation is generally not a problem with a high DC fluid application because when the transmitter loses its echo, it cannot “see” the centering disc through the fluid and therefore enters the transmitter’s “alarm” mode (generally set High @ 21 mA).
- B. **ALARM** – As the level increases as described in SATURATION above, when the level increases such that the transmitter loses the echo from the real level (output is 20.56 mA), the transmitter is prevented from “seeing” the centering disc below the engineering units entered in LRM. If the transmitter sees no echo, it will enter its alarm state (21 mA) as programmed by the jumpers on the face of the module. The transmitter’s output now simply increases from 20.56 mA (out of range saturation – high) to 21 mA (Transmitter Failure Alarm – High), preventing any control upset. When the level drops and the transmitter re-acquires the true level echo, the transmitter’s output will change from 21 mA (Failure Alarm high) to 20.56 mA (measurement out of range –high), and then track the level downward to 20 mA (URV) and normal operation.
  - **LRM (only if SOR is set to ALARM)** – Low Range Margin – the limiting distance below LRV (4.0 mA value) at which a valid echo will be recognized. This value is displayed and can be changed only when ALRM is selected. LRM is a positive value and can be up to 50% of sensor trim span. This value is not critical and is typically set at 4.0” (10cm).

## 5.0 Safety, Maintenance and Troubleshooting

The MT5000 will operate normally without the need for periodic maintenance or inspection. If the transmitter meets or exceeds the requirements of the application, the transmitter can be expected to provide reliable level indication for a minimum of 10 years.

If the MT5000 transmitter is being used as part of a Safety Implemented System (SIS), periodic testing will be required to proof the transmitter and detect any potential failure which is defined as Dangerous Undetectable in normal operation. Proof testing must be performed at regular intervals (2 years) and the results of this testing must be documented. Should the transmitter exhibit a fault during normal operation, it will be necessary to perform the proof testing regardless of schedule. As part of the testing documentation, all parameters included in the menu structure of the transmitter (see page 10) as well as the configuration of the module jumpers (see page 9) must be recorded. The transmitter is capable of supplying (1) 4-20mA output. If a transmitter is equipped with more than one indication, only the process variable selected by the PV= menu option will be considered as a safety function as this selected variable will be the basis for the 4-20mA output. The MT5000 transmitter may only be used in a safety-related system when the mode of that system is low demand. As a device, the MT5000 transmitter will be used to provide a level measurement to prevent overflow and dry run of a vessel.

If a transmitter fails an inspection or assistance is required for inspection or troubleshooting, contact the Service Department at ABB via e-mail at [service@ktekcorp.com](mailto:service@ktekcorp.com). The Service Department will answer questions, provide additional assistance, and issue Return Authorization Numbers for equipment in need of repair.

**CAUTION:** In the event a guided wave radar transmitter has suffered a failure in any component which is exposed to the process, any other guided wave radar transmitter installed in the same or similar process should be inspected for the same failure regardless of its maintenance schedule. These Common Cause Failures include: 1) Damage to the high frequency coupler, 2) damage to the electronics module, 3) deformation of the sensor probe due to process agitation.

Notes on usage in Safety Instrumented Systems:

- 1) The MT5000 performs internal diagnostics at a maximum interval of 15 minutes.
- 2) The MT5000 will provide annunciation of a diagnostic failure in less than 15 minutes of the occurrence.
- 3) The failure of any internal diagnostics will result in notification of the fault by setting of diagnostic bits in HART protocol output.
- 4) All MT5000 FMEDA analysis is based on using a safety accuracy of 2%.
- 5) The internal diagnostics are designed to achieve a Safe Failure Fraction of 90% minimum.
- 6) The target average probability of failure on demand is less than  $1.5 \times 10^{-3}$ .
- 7) MT5000 transmitters may only be used in a SIS when they are fitted with a 4-20 mA output HART Protocol /M7A or M7B and are software version 090414.00.001 Electronic Module or higher.

### 5.1 Personnel Qualifications

Safety Inspection, Maintenance and Troubleshooting should only be performed by qualified personnel. These qualifications include a knowledge of the information in this instruction manual, knowledge of the product and its operating principles, knowledge of the application in which the transmitter is being applied, and general experience as an Instrument Technician.

Before, during and after performing Safety Inspection, Maintenance or Troubleshooting it will be necessary to observe and adhere to any safety standards, practices or requirements defined in the policies of the end user.

### 5.2 Required Tools

The following tools may be required to perform inspection, maintenance or troubleshooting of the MT5000 transmitter.

- Crescent Wrenches or box end wrenches
- Screwdrivers
- Hex Key Wrenches
- Calibrated Digital Multi-meter
- Tape Measure
- Calibrated Portable Oscilloscope (optional)



### 5.3 Suggested Proof Test

The suggested proof test consists of minimum and maximum current capability test followed by a two-point calibration of the transmitter, see the suggested proof test Table. This test will detect > 99% of possible DU failures in the device.

**MT5000 Suggested Proof Test Table**

1.	Bypass the safety function in the control system and take appropriate action to avoid a false trip.
2.	Use HART communications to retrieve any diagnostics and take appropriate action.
3.	Send a HART command to the transmitter to go to the high alarm current output and verify that the analog current reaches that value.*
4.	Send a HART command to the transmitter to go to the low alarm current output and verify that the analog current reaches that value. **
5.	Perform a two-point calibration*** of the transmitter over the full working range.
6.	Remove the bypass and otherwise restore normal operation.

Notes:

- \* This tests for compliance voltage problems such as a low loop power supply voltage or increased wiring resistance. This also tests for other possible features.
- \*\* This tests for possible low current related failures.
- \*\*\* If the two-point calibration is performed with electrical instrumentation, this proof test will not detect any failures of the sensor.

### 5.4 Safety Inspection & Test

An MT5000 transmitter can be divided into three major components, the sensor, the transmitter, and the output. All of these components and their subcomponents should be evaluated during each periodic inspection. This inspection (and possible repair) should take less than 4 hours if the proper tools are made available. Prior to inspection, the transmitter should be removed from service following end user specified procedures regarding lockout, tag out, wiring and cleaning. Once removed from service, the MT5000 transmitter should be laid on a flat even surface.

### 5.4.1 Sensor Inspection

The rod or cable assembly should not be damaged or corroded in any way. Additionally, it should not be touching any of the surrounding tank or chamber surfaces in the measurement range.

### 5.4.2 Transmitter Testing

The transmitter of the MT5000 is designed to return a level indication and an output based on a dielectric constant change between the upper fluid or vapor and the lower fluid. If the transmitter is equipped with an LCD the level and output will be displayed on the front of the electronics module.

- 1) Apply power to the transmitter using the typical power setup for the particular option.
- 2) Move a high dielectric object such as a metal target plate up and down the sensor.
- 3) Monitor the indication of the level on the LCD to make sure the indication corresponds to the target position.
- 4) Make sure the transmitter responds with an Alarm Indication (based on the jumper position) and a corresponding level indication based on your setup (HIGH = 21.00 mA, LOW = 3.61 mA)

Note: It is possible for the MT5000 to continue providing a 4-20mA output if the LCD display is not functioning properly. If the LCD indicator on an electronics module fails to operate, it is recommended that the electronics module be replaced at the earliest convenience. It will not be necessary however to shut down a transmitter or remove it from service based on an LCD failure.

### 5.4.3 Output Checkout

The MT5000 can be equipped to provide level indication through the 4-20mA output, HART communications, Foundation Fieldbus, or Modbus. Only transmitters that are specified to output 4-20mA may be used in a Safety Implemented System. The HART communication capability of the 4-20mA transmitter will only be used for configuration and proof testing.

#### 5.4.3.1 4-20mA Output

The current output of the MT5000 transmitter updates at least every 110 milliseconds and is filtered through the user adjusted Damping. The maximum response time to a process change will be less than 110 milliseconds or the value of the Damping, whichever is greater.

1. Apply power to the transmitter using the typical loop wiring diagram.
2. Connect a multi-meter (set to read milliamps) to the transmitter using the —Meterll connections on the terminal strip.
3. Move a high dielectric object such as a target plate along the length of the probe and monitor the milliamp output on multi-meter .
4. The output should indicate the target position based on the calibration range of the transmitter.

#### 5.4.3.2 HART Output

1. Apply power to the transmitter using the typical loop wiring diagram.
2. Connect a HART handheld device across a 250 ohm resistor in series with the loop.
3. Move the target along the length of the probe and monitor the PV indication on the handheld device.
4. The output should indicate the target position based on the calibration range of the transmitter.

Note: A HART handheld device will communicate with the MT transmitter as a Generic Device. If the output of the transmitter becomes latched, the HART handheld will respond with a warning that the Process Variable is out of range. To overcome the error, press OK when prompted to —ignore the next 50 occurrences. ll

### **5.4.3.3 4-20mA Loop Check**

#### **Without HART**

LOOP TEST is a function designed to simulate transmitter output at various levels and confirm readings from a separate location. The LOOP TEST may be performed at any mA OUTPUT between 3.61 and 21.00. To perform a LOOP TEST: 1. Press and hold the SELECT button for 2 seconds. 2. Scroll UP or DOWN to select each digit for the desired mA OUTPUT. 3. Press the SELECT button to set the digit and move to the next digit in sequence. 4. After the last digit is set the mA OUTPUT will change to the desired level. (Another mA OUTPUT may be selected by repeating steps 1 through 4.) 5. Scroll DOWN to END MENU. (The mA OUTPUT will return to normal operation after pushing the DOWN arrow) 6. Pressing the SELECT button now will return you to the main screen.

#### **With HART communications**

With the transmitter installed, wired and powered in its field location and power supplied to the loop, connect a HART handheld device to the loop across a 250 ohm resistor. Using the Loop Test feature of the HART handheld, drive the output of the transmitter to 4mA and 20mA. Confirm the proper reading at the indication or control side of the loop. Minor adjustments to the output of the transmitter may be made using the DAC Trim (Digital/Analog Converter) feature.

During normal operation, it is not necessary to perform maintenance on the MT5000 transmitter. Routine calibration of the transmitter is not necessary. The MT5000 contains an EPROM which will store calibration in case of an outage or electronics replacement.

### **5.5 Verify Proper Power-up of the Transmitter**

Use a mA meter to measure the output current. When power is applied, the output should go to 4.00 mA for at least 1 second, and then to either the measured level or an alarm condition output. If this does not happen, the transmitter may not be receiving enough power, or the main electronic is defective. Excessive current above 21 mA is also an indication of improper power-up or defective electronics.

### **5.6 Module Replacement or Upgrade**

The MT5000 transmitter is equipped with modular electronics which may be removed from the housing. An EPROM located in the transmitter housing will maintain the settings of the transmitter if the electronics are removed. This allows the replacement of failed electronic modules and upgrading of electronics or transmitter software without losing calibration and setup configuration.

Before removing the electronics module for replacement or upgrade, the MT5000 transmitter should be taken out of service. To remove the electronics module, simply loosen the 2 mounting screws, unplugging the module from the housing and replace it with the new module.

The software revision of a transmitter can be identified by a tag on the back of the electronics module. The date code of the software revision will appear as a series of numbers such as MT 090414.00.001. The type of module will be identified on the same tag with a code such as M7A-MT5 or M7B-MT5.

**WARNING:** In order to maintain certification requirements, repair of the instrument at the electronic component level can only be performed at the factory. Field repair of electronics components should only involve replacing electronic modules. Opening the electronics module will void all warranties of the transmitter.

## 5.8 Symptoms and Solutions

Symptom	Possible Cause	Solution
Output spiking high	<ul style="list-style-type: none"> <li>Blanking area too short</li> </ul>	<ul style="list-style-type: none"> <li>Verify proper nozzle length in BASIC SETUP menu (SECTION 4.3.5)</li> <li>From the WAVEFORM AT COUPLER display extend the Blanking (BLK) past obstructions (Section 4.6.1)</li> </ul>
	<ul style="list-style-type: none"> <li>Threshold voltage too high</li> </ul>	<ul style="list-style-type: none"> <li>From the WAVEFORM display readjust the LTV from the return signal (Section 4.6.1)</li> </ul>
Output too low	<ul style="list-style-type: none"> <li>Inadequate supply voltage</li> </ul>	<ul style="list-style-type: none"> <li>Check power supply voltage</li> </ul>
	<ul style="list-style-type: none"> <li>Current drain in wiring</li> </ul>	<ul style="list-style-type: none"> <li>Check wiring for ground faults or water in conduit</li> </ul>
No display and no mA output	<ul style="list-style-type: none"> <li>Inadequate supply voltage</li> </ul>	<ul style="list-style-type: none"> <li>Check power supply voltage</li> <li>Check wiring connections to transmitter and power supply</li> </ul>
	<ul style="list-style-type: none"> <li>Electronics failure</li> </ul>	<ul style="list-style-type: none"> <li>Replace electronics module (Section 5.3)</li> </ul>
No display with mA output	<ul style="list-style-type: none"> <li>Electronics failure</li> </ul>	<ul style="list-style-type: none"> <li>Replace electronics module (Section 5.3)</li> </ul>
Actual mA output does not match displayed value	<ul style="list-style-type: none"> <li>Improper DAC trim</li> </ul>	<ul style="list-style-type: none"> <li>Perform DAC trim (Section 4.5.6)</li> </ul>
	<ul style="list-style-type: none"> <li>Shorted RFI filters in terminal strip</li> </ul>	<ul style="list-style-type: none"> <li>Replace terminal strip</li> </ul>
Unit worked until new IS barrier was installed	<ul style="list-style-type: none"> <li>Barrier does not meet requirements for the transmitter</li> </ul>	<ul style="list-style-type: none"> <li>Verify barrier specifications to match ELE1014</li> </ul>
Upon power up current output drops to 4mA before dreading correct level	<ul style="list-style-type: none"> <li>Normal operation</li> </ul>	<ul style="list-style-type: none"> <li>Normal Operation</li> </ul>

## 5.9 Electronics Module Replacement

A defective electronics module can be replaced as follows:

1. Disconnect the supply power from the MT5000.
2. Remove the existing module by unscrewing the two slotted screws holding the module in the housing.
3. Note the orientation of the module and unplug from the housing base.
4. Carefully unplug the coax cable connector from side of the module.
5. Plug the coax cable into the new module.
6. Plug module onto the housing base.
7. Secure the module to the housing by screwing the two flat screws.
8. Reconnect the supply power the MT5000.
9. If a minor error in measured level is detected, the error may be compensated for using the LVL OFFSET function in the BASIC SETUP menu. (Section 4.3.6.) or by performing a sensor reference calibration.

The MT5000 is now ready for use without further calibration.

The software revision of a transmitter can be identified by a tag on the back of the electronics module. The date code of the software revision will appear as a series of numbers such as X\_H\_090209 or X\_H\_TS\_090209. The type of module will be identified on the same tag with a code such as M7A, M7B or X.

# 6.0 Installation Drawings for Intrinsic Safety & Standard Wiring

Reference ABB drawing ELE1014 MT2000 Series, Intrinsically Safe Electrical Interconnection Diagram.

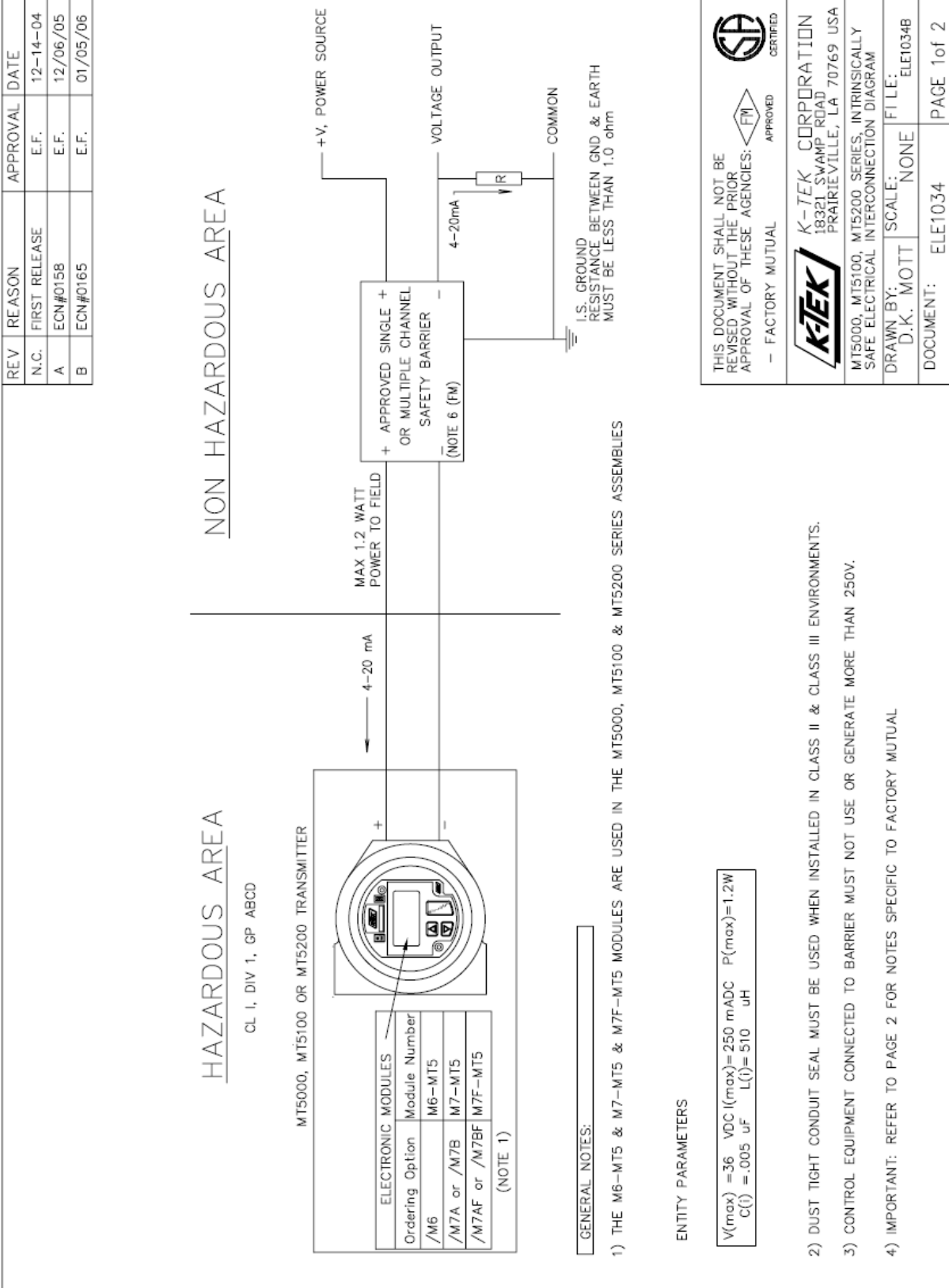

# Installation Drawings for Intrinsic Safety & Standard Wiring (continued)

Reference ABB drawing ELE1014 MT2000 Series, Intrinsically Safe Electrical Interconnection Diagram.

REV	REASON	APPROVAL	DATE
N.C.	FIRST RELEASE	E.F.	12-14-04
A	ECN#0158	E.F.	12/06/05
B	ECN#0165	E.F.	01/05/06

<p><b>NOTES RELATED TO FM APPROVAL:</b></p> <p>5) THE ELE9011 - ELE9012 MODULES CONFORMS TO FMRC APPROVAL STANDARD NO.3610.</p> <p>6) SAFETY BARRIER MUST MEET THE FOLLOWING REQUIREMENTS:  <math>V_{(oc)} \text{ or } V_{(t)} \leq V_{(max)}</math>, <math>I_{(sc)} \text{ or } I_{(t)} \leq I_{(max)}</math>, <math>C(o) &gt; (C(i) + C_{(cable)})</math>, <math>L(o) &gt; (L(i) + L_{(cable)})</math></p> <p>7) FOR DIV 2 APPLICATIONS, THE TRANSMITTER MUST EITHER BE INSTALLED IN ACCORDANCE WITH NATIONAL ELECTRICAL CODE FOR DIVISION 2 WIRING METHODS OR CONNECT TO AN FMRC APPROVED BARRIER.</p> <p>8) ASSOCIATED EQUIPMENT MUST BE FMRC APPROVED.</p> <p>9) NONINCENDIVE FIELD WIRE PARAMETERS:          ENTITY PARAMETERS  <math>V_{(max)} = 36 \text{ VDC}</math> <math>I_{(max)} = 90 \text{ mADC}</math> <math>P_{(max)} = 1.2W</math>  <math>C(i) = .005 \mu F</math> <math>L(i) = 510 \mu H</math></p> <p>10) INSTALLATION SHALL BE IN ACCORDANCE WITH ANSI/ISA RP12.6 AND THE NEC ANSI/NFPA 70.</p> <p>11) SYSTEM CALCULATIONS: ADD CABLE CAPACITANCE &amp; INDUCTANCE TO TRANSMITTER ENTITY PARAMETERS (I.E., ALL FIELD INSTALLED CAPACITANCE &amp; INDUCTANCE MUST BE CONSIDERED).          IF CABLE PARAMETERS ARE NOT KNOWN, 60pF/ft &amp; 0.2uH/ft SHOULD BE USED.</p>	<p><b>NOTES RELATED TO CSA CERTIFICATION:</b></p> <p>A) SAFETY BARRIER MUST MEET THE FOLLOWING REQUIREMENTS:  <math>V_{(oc)} \leq V_{(max)}</math>, <math>I_{(sc)} \leq I_{(max)}</math>, <math>C(o) &gt; (C(i) + C_{(cable)})</math>, <math>L(o) &gt; (L(i) + L_{(cable)})</math>          ONE CERTIFIED DUAL CHANNEL OR TWO SINGLE CHANNEL BARRIERS MAY BE USED WHERE BOTH CHANNELS HAVE BEEN CERTIFIED FOR USE TOGETHER WITH COMBINED ENTITY.</p> <p>B) FOR DIV 2 APPLICATIONS, THE TRANSMITTER MUST BE INSTALLED IN ACCORDANCE WITH CANADIAN ELECTRICAL CODE PART 1 (C22.1) FOR DIVISION 2 WIRING METHODS.</p> <p>C) ASSOCIATED EQUIPMENT MUST BE CSA CERTIFIED.</p> <p>D) INSTALLATION SHALL CONFORM TO THE INSTRUCTIONS SUPPLIED WITH SAFETY BARRIERS, AND TO THE C.E.C. PART I.</p> <p>E) ADDITIONAL NOMENCLATURE: Exia - INTRINSICALLY SAFE - SECURITE INTRINSEQUE</p> <p>F) WARNING: SUBSTITUTION OF COMPONENTS MAY IMPAIR SUITABILITY FOR USE IN HAZARDOUS LOCATIONS.          AVERTISSEMENT: LA SUBSTITUTION DE COMPOSANTS PEUT RENDRE CE MATERIEL INACCEPTABLE POUR LES EMPLOIS DANGEREUX.</p> <p>G) WARNING: EXPLOSION HAZARD - DO NOT DISCONNECT EQUIPMENT UNLESS POWER HAS BEEN SWITCHED OFF OR THE AREA IS KNOWN TO BE NON-HAZARDOUS.          AVERTISSEMENT: RISQUE D'EXPLOSION - AVANT DE DISCONNECTER L'EQUIPEMENT, COUPER LE COURANT OU S'ASSURER QUE L'EMPLACEMENT EST DESIGNE NON DANGEREUX.</p>
--	--

<p>THIS DOCUMENT SHALL NOT BE REVISED WITHOUT THE PRIOR APPROVAL OF THESE AGENCIES:          - FACTORY MUTUAL APPROVED</p>	<p>THIS DOCUMENT SHALL NOT BE REVISED WITHOUT THE PRIOR APPROVAL OF THESE AGENCIES:          - FACTORY MUTUAL CERTIFIED</p>
--	---

<p><b>K-TEK</b></p> <p>K-TEK CORPORATION          18321 SWAMP ROAD          PRAIRIEVILLE, LA 70769 USA</p>	<p>MT5000, MT5100, MT5200 SERIES, INTRINSICALLY SAFE ELECTRICAL INTERCONNECTION DIAGRAM</p>
--	---

<p>DRAWN BY: D.K. MOTT</p> <p>SCALE: NONE</p> <p>DOCUMENT: ELE1034</p>	<p>FILE: ELE1034B</p> <p>PAGE 2 of 2</p>
--	--

## 7.0 Installation Drawings for Explosion Proof

Reference ABB drawing ELE1015 MT2000 or MT5000 Loop Powered TX Hookup Dual Compartment Housing.



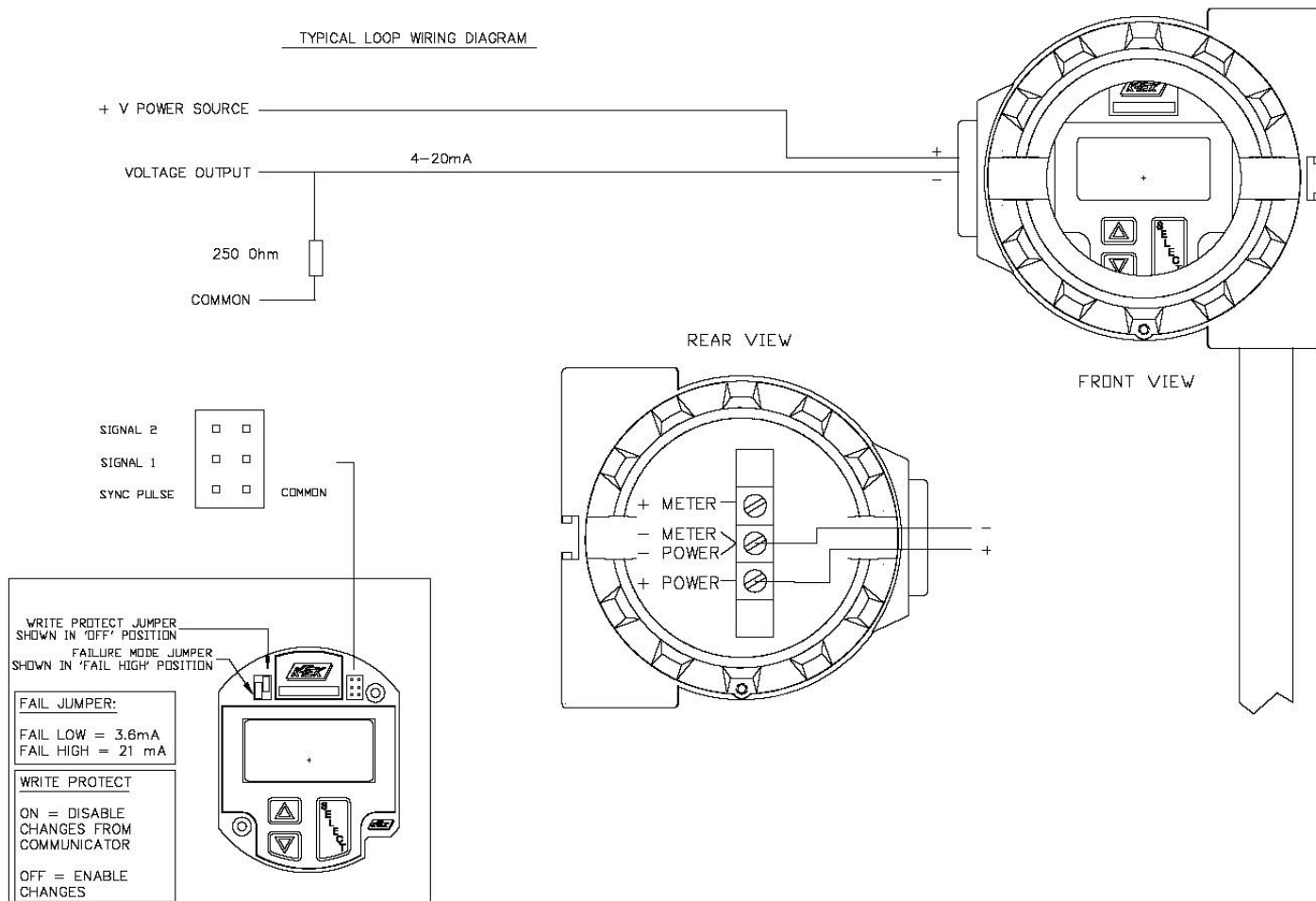

## EU DECLARATION OF CONFORMITY

### The EU Directives covered by this Declaration:

89/336/EEC Electromagnetic Compatibility Directive, amended by 92/31/EEC & 93/68/EEC  
Pressure Equipment Directive (PED) 97/23/EC

### The Products Covered by this Declaration:

**MT5000, MT5100, and MT5200 Series, 2 Wire Loop Powered, Guided Wave Radar Level Transmitters**

### The Basis on which Conformity is being declared:

The product identified above complies with the requirements of the above EU Directives by meeting the following standards:

EN61326 A1/A2/A3	Electromagnetic Radiated Emission
EN61000-4	Electrostatic Discharge, Radiated Immunity, Transients, Surge and Conducted Immunity.
EN287/288	Welding

The technical documentation required to demonstrate that the product meets the requirements of the Low Voltage Directive has been complied by the signatory below and is available for inspection by the relevant enforcement authorities. The CE mark was first applied in 2007

The products described above comply with the essential requirements of the directives specified.

Signed: Eric P. Fauveau

Authority: Vice President Research & Development

Date: January 8, 2010

### ATTENTION!

The attention of the specifier, purchaser, installer, or user is drawn to the following special measures and limitations to use which must be observed when the product is taken into service to maintain compliance with the above directives:

- 1) Proper Installation of the instrument requires use of shielded cable for the loop wiring, and mounting to an electrically shielded tank.

Details of these special measures and limitations are also contained in the product manuals.

## 9.0 CUSTOMER SUPPORT

### **ABB (USA, Canada, International)**

18321 Swamp Road  
Prairieville, LA 70769 USA  
Tel: +(1) 225.673.6100  
Fax: +(1) 225.673.2525  
Email: [service@ktekcorp.com](mailto:service@ktekcorp.com)  
Website: [abb.com/level](http://abb.com/level)



## 9.1 ABB RMA FORM



ABB  
 18321 Swamp Road  
 Prairieville, LA 70769  
 Phone: +1 (225) 673-6100  
 Fax: +1 (225) 673-2525  
 Email: service@ktekcorp.com  
 Toll Free: (800) 735-5835

**\*\*\* IMPORTANT CUSTOMER NOTICE: PLEASE READ PRIOR TO RETURNING PRODUCTS TO ABB\*\*\***

Be sure to include the Return Authorization (RA) number on the shipping label or package to the attention: Customer Service. A copy of this document should also be included with the packing list. ABB wants to maintain a safe work environment for its employees. In the event, the returned product or material has been in contact with a potentially hazardous chemical, per federal regulations, the customer must provide evidence of decontamination and the related chemical composition and characteristics. In order to expedite your return, please include the applicable Material Safety Data Sheets (MSDS) and decontamination tags by affixing these documents in close proximity to the shipment label for identification purposes. (January 18, 2006)

Return Authorization Form	
Customer:	Date:
Contact Name:	Product:
Contact Email:	Serial No:
Contact Phone:	Job No:
Contact Fax:	Service Rep:

### Completed by Customer

Reason

Problem Found: None

Action: None

Requested:

Is expedited return shipping requested?  Yes  
*If yes, please provide a purchase order or your shipper's account number (ex. FedEx or UPS). ABB pays return transport via standard ground shipments only.*

***If purchase order is issued, a copy of purchase order must be included with return documentation.***

Is ABB authorized to repair items determined to be non-warranty?  Yes  
*If yes, a copy of purchase order must be included with return documentation.*

Customer PO:  Date:

Account #:

Has product been in contact with any potentially hazardous chemical?  Yes  
*If yes, documentation product and forward MSDS to ABB, "ATTN: Customer Service"*

### Return Repaired Product to Address

Shipping Address:	Billing Address:
	Ship Via: <input type="text"/>

## 10.0 WARRANTY

### 5 YEAR WARRANTY FOR:

KM26 Magnetic Liquid Level Gauges; MagWave Dual Chamber System; LS Series Mechanical Level Switches (LS500, LS550, LS600, LS700, LS800 & LS900); EC External Chambers, STW Stilling Wells and ST95 Seal Pots.

### 3 YEAR WARRANTY FOR:

KCAP300 & KCAP400 capacitance switches. BETA Pressure and Temperature Switches have a limited factory guarantee, excluding wetted parts & consumables.

### 2 YEAR WARRANTY FOR:

AT100, AT100S and AT200 series transmitters; RS80 and RS85 liquid vibrating fork switches; RLT100 and RLT200 reed switch level transmitters; TX, TS, TQ, IX and IM thermal dispersion switches; IR10 and PP10 External Relays; MT2000, MT5000, MT5100 and MT5200 radar level transmitters; RI100 Repeat Indicators; KP paddle switches; A02, A75 & A77 RF capacitance level switches and A38 RF capacitance level transmitters; Buoyancy Level Switches (MS50, MS10, MS8D & MS8F); Magnetic Level Switches (MS30, MS40, MS41, PS35 & PS45).

### 1 YEAR WARRANTY FOR:

KM50 gauging device; AT500 and AT600 series transmitters; LaserMeter and SureShot series laser transmitters; LPM200 digital indicator; DPM100 digital indicators; APM100 analog indicators; KVIEW series digital indicators and controllers; SF50 and SF60 vibrating fork switches, KB Electro-Mechanical Continuous Measuring Devices, KSONIK ultrasonic level switches, transmitters & transducers, ChuteMaster Microwave Transmitter / Receiver and TiltMaster Switches.

### SPECIAL WARRANTY CONSIDERATIONS:

ABB does not honor OEM warranties for items not manufactured by ABB (i.e. Palm Pilots). These claims should be handled directly with the OEM.

ABB will repair or replace, at ABB's election, defective items which are returned to ABB by the original purchaser within the period specified above from the shipment date of the item and which is found, upon examination by ABB, to its satisfaction, to contain defects in materials or workmanship which arose only under normal use and service and which were not the result of either alterations, misuse, abuse, improper or inadequate adjustments, applications or servicing of the product. ABB's warranty does not include onsite repair or services. Field service rates can be supplied on request.

If a product is believed to be defective, the original purchaser shall notify ABB and request a Returned Material Authorization before returning the material to ABB, with transportation prepaid by the purchaser. (To expedite all returns/repairs from outside of the United States, consult ABB's customer service team ([service@ktekcorp.com](mailto:service@ktekcorp.com)) to determine an optimal solution for shipping method and turnaround time.) The product, with repaired or replaced parts, shall be returned to the purchaser at any point in the world with transportation prepaid by ABB for best-way transportation only. ABB is not responsible for expedited shipping charges. If the product is shipped to ABB freight collect, then it will be returned to the customer freight collect.

If inspection by ABB does not disclose any defects in material or workmanship, ABB's normal charges for repair and shipment shall apply (minimum 250.00 USD).

The materials of construction for all ABB products are clearly specified and it is the responsibility of the purchaser to determine the compatibility of the materials for the application.

THE FOREGOING WARRANTY IS ABB'S SOLE WARRANTY AND ALL OTHER WARRANTIES EXPRESSED, IMPLIED, OR STATUTORY, INCLUDING ANY IMPLIED WARRANTY OF MERCHANTABILITY OF FITNESS FOR A PARTICULAR PURPOSE, ARE EXCLUDED AND NEGATED TO THE MAXIMUM EXTENT PERMITTED BY LAW. NO PERSON OR REPRESENTATIVE IS AUTHORIZED TO EXTEND ANY OTHER WARRANTY OR CREATE FOR ABB ANY OTHER LIABILITY IN CONNECTION WITH THE SALE OF ABB'S PRODUCTS. THE REMEDIES SET FORTH IN THIS WARRANTY ARE EXCLUSIVE OF ALL OTHER REMEDIES AGAINST ABB. ABB SHALL NOT BE LIABLE FOR ANY CONSEQUENTIAL, INCIDENTAL, OR SPECIAL DAMAGES OF ANY KIND. ABB'S SOLE OBLIGATION SHALL BE TO REPAIR OR REPLACE PARTS (FOUND TO BE DEFECTIVE IN MATERIALS OR WORKMANSHIP) WHICH ARE RETURNED BY THE PURCHASER TO ABB.







# Contact us

## **ABB US**

18321 Swamp Road  
Prairieville, LA 70769  
USA

Tel: +1 225 673 6100

Fax: +1 225 637 2525

**[www.abb.com/level](http://www.abb.com/level)**

## Note

We reserve the right to make technical changes or modify the contents of this document without prior notice. With regard to purchase orders, the agreed particulars shall prevail. ABB does not accept any responsibility whatsoever for potential errors or possible lack of information in this document.

We reserve all rights in this document and in the subject matter and illustrations contained therein. Any reproduction, disclosure to third parties or utilization of its contents - in whole or in parts - is forbidden without prior written consent of ABB.

Copyright© 2012 ABB  
All rights reserved

OMMT5000-EN Rev. H 05.2013