

# *TOSVERT VF-AS3*

## My function Manual

**TOSHIBA INDUSTRIAL PRODUCTS AND SYSTEMS CORPORATION**

NOTICE

1. Read this manual before installing or operating the inverter. Keep it in a safe place for reference.
2. All information contained in this manual will be changed without notice.



**CONTENTS**

1. Introduction .....	1
2. Parameters used .....	1
3. Summary of My function .....	1
4. Setting parameters .....	3
5. Examples of setting .....	12
6. Analog input My function .....	25
7. Analog output My function .....	29
Appendix 1 Table of My function parameters .....	30
Appendix 2 Computing functions .....	35
Appendix 3 Input terminal function select parameters .....	37
Appendix 4 Output terminal function select parameters .....	40
Appendix 5 Internal data .....	45
Appendix 6 Examples of computing function settings .....	50



# 1. Introduction

My function adds programming capability to inverter's input/output signals without external relays or a PLC (programmable logic controller) in some cases.

The function makes it possible to reduce the space and cost required for the system.

# 2. Parameters used

My function uses the parameters [A800] to [A847], [A900] to [A982].

→ For details of each parameter, refer to the relevant section.

# 3. Summary of My function

My function has the relay sequence function that combines logic operation functions.

When an inverter is controlled by a PLC (programmable logic controller), the PLC receives, processes, and sends the signals as processing result to the inverter.

(See Fig 3-1.)

The relay sequence function enables the inverter to perform itself in 52 steps (4 steps x 7 units + 24 steps) without a PLC.

Because the function uses internal data and signals directly, the processing speed is faster than control with the PLC. Furthermore, the function enables the inverter to use its multi-function input and output signals at the same time, and thus to perform various operations in a reduced number of steps.

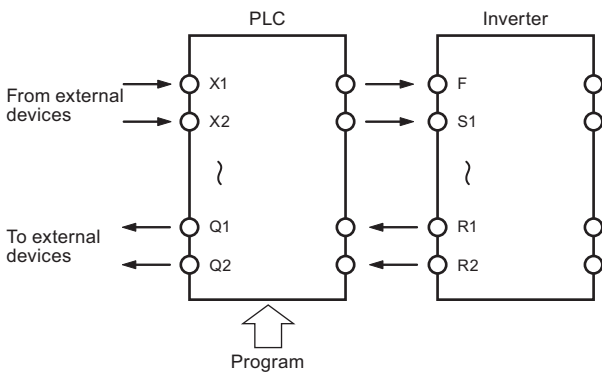

Fig. 3-1 Signal flow between PLC and inverter

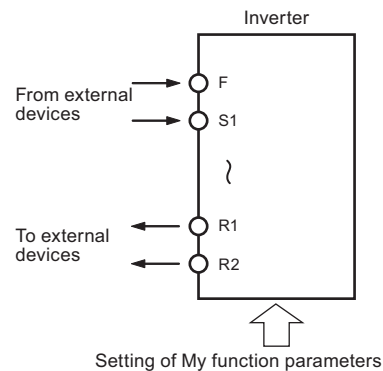
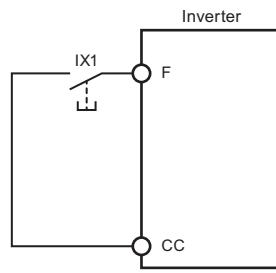

Fig. 3-2 Signal flow of inverter with My function

**Example:** Start forward run with a push switch (non self hold switch).  
 Stop automatically when the output current is 120% or more of the rated current when the output frequency is 5Hz or less.  
 For the sake of simplicity, stop signal input terminals are omitted here.  
 See Example 6 in Chapter 5 for details.

- **Input and output connection**



- **Timing chart**

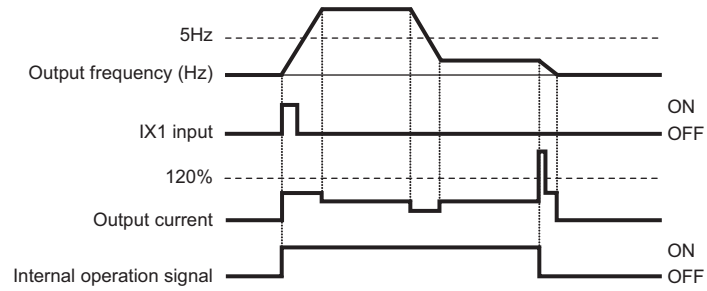

## 4. Setting parameters

This chapter explains how to set parameters related to My function using the composition of My function and the rules.

### Input terminals

Input signal terminals that can be used with My function are as follows;

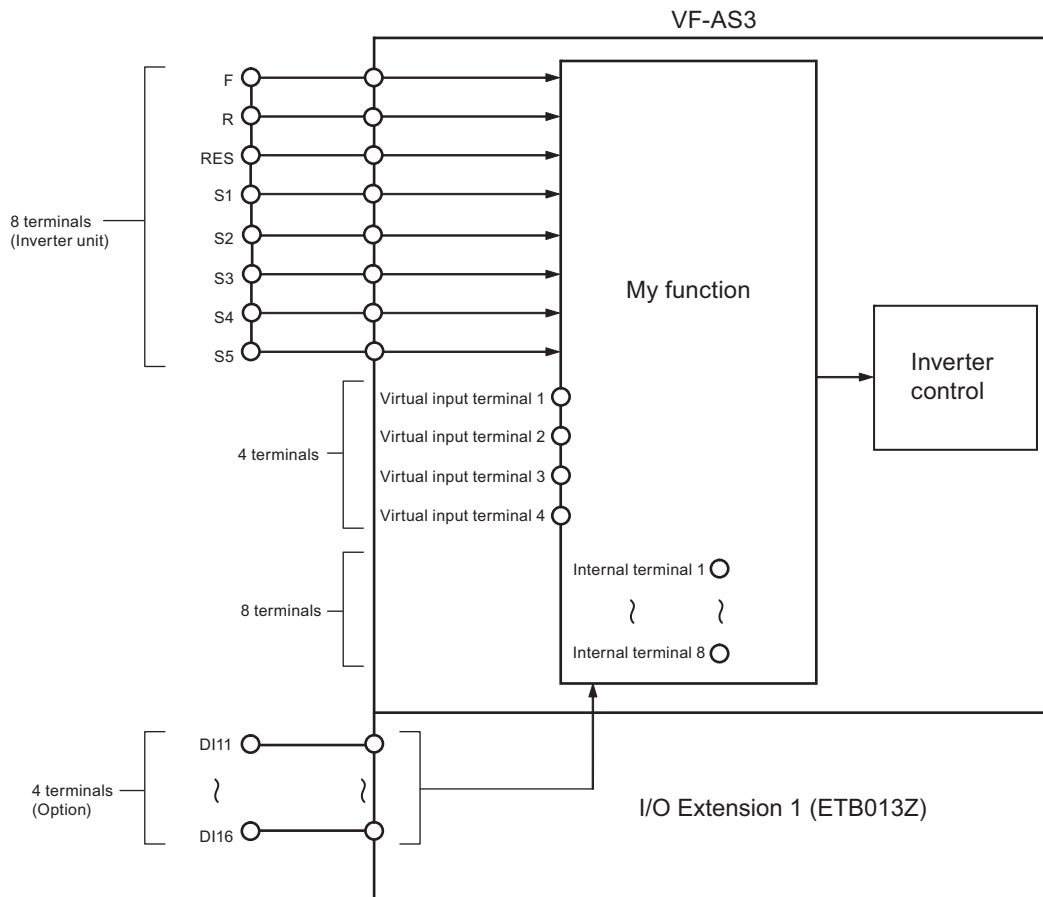

- Input terminals (14 terminals: F, R, RES, S1, S2, S3, S4, S5, LI11, LI12, LI13, LI14, LI15, LI16)**  
 VF-AS3 has 14 input terminals (6 terminals for option).  
 The input terminals are used for following 2 ways.

  - 1) Input terminals to which assign multiple functions
  - 2) Simple ON/OFF signal input terminals like a PLC

In this manual, such input terminals are referred to as X1, X2 to X16 to distinguish them from case 1).
- Virtual input terminals (4 terminals)**  
 Virtual input terminals cannot be turned on and off electronically unlike actual input terminals. Virtual input terminals can be turned on and off using communication function or My function. You can assign the multiple functions as same as actual input terminals.
- Internal terminals (8 terminals)**  
 Internal terminals cannot be turned on and off electronically unlike actual input terminals. Internal terminals can be turned on and off using communication function or My function. You can not assign the multiple functions as same as the virtual input terminals. They correspond to the internal relay used in PLC. They are used for preserving and reading the status.

■ **Computing function**

My function can perform logical operations on input/output signals and compares and computes some data, such as frequency, current, and torque data that the inverter detects.

A table of computing functions is shown in Appendix 2.

Available data that the inverter detects are listed in Appendix 5.

• **Logical comparison**

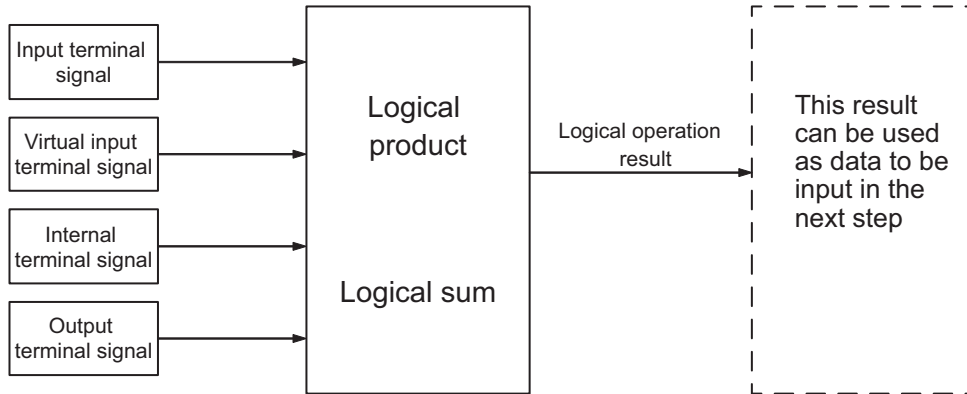

• **Commutation**

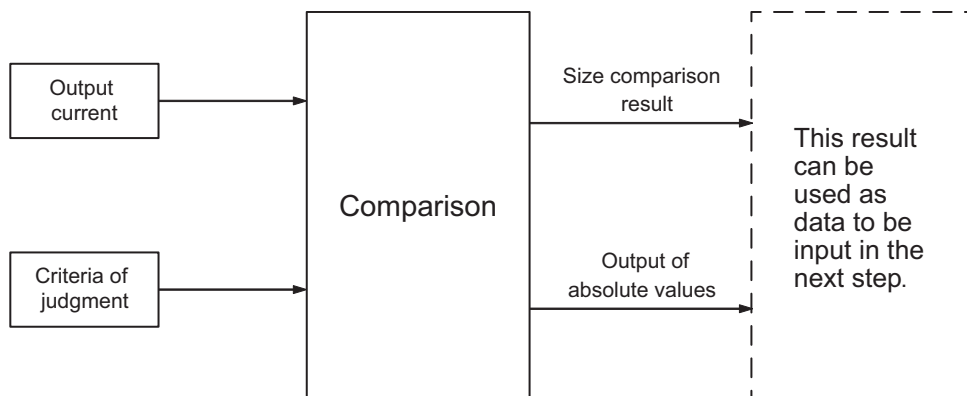



■ **Output terminals**

Output signal terminals used with My function are following.

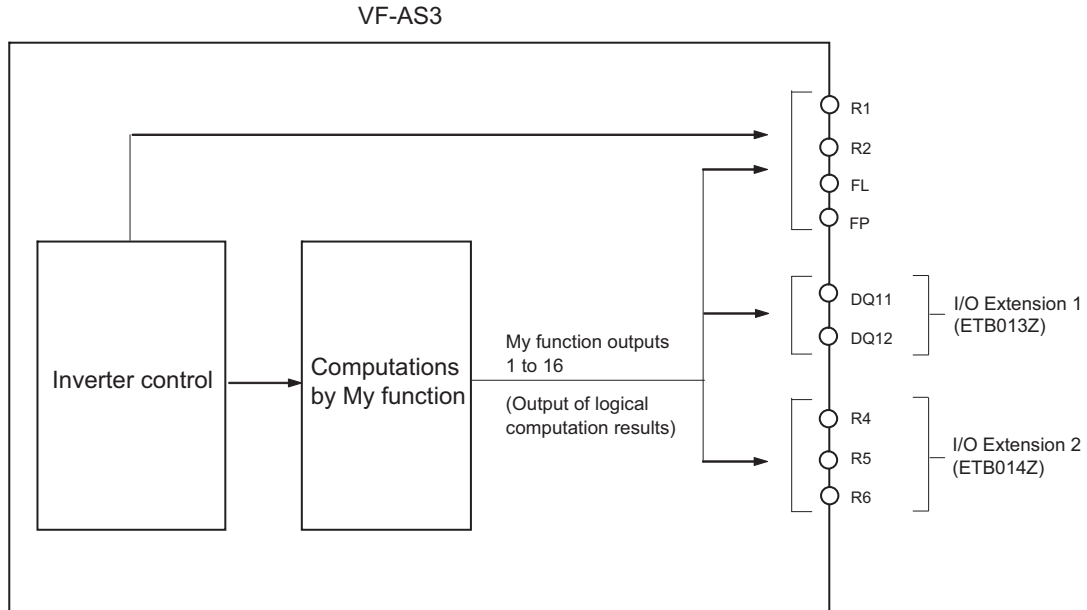

• **Output terminals (9 terminals: R1, R2, FL, FP, DQ11, DQ12, R4, R5, R6)**

VF-AS3 has 9 output terminals (5 terminals for option).

You can assign the multiple functions to the output terminals.

A table of output terminal functions is shown in Appendix 4. Only the positive logic settings are used for My function.

**Note:** Negative logic settings of output terminal functions cannot be used for the My function.

Computation results can be output by assigning the My function output 1 to 16 to the output terminals.

■ **Setting parameters**

My function has 4 steps x 7 units + 24 steps. Each step consists of one command. My function begins with a data load (LD) command and ends with a data store (ST).

[A900] to [A982] consists of 4 steps x 7 units, and therefore there are 28 steps in total. See Fig.4-1 for the composition of each unit. Each unit begins with a data load (LD) command as step 1 and ends with a data store (ST) command as step 4. (You don't need to set LD command and ST command.) You set the commands and objects to step 2 and 3 in accordance with the requested functions.

[A800] to [A847] consists of 24 steps. You need to set LD command for beginning and set ST command for end.

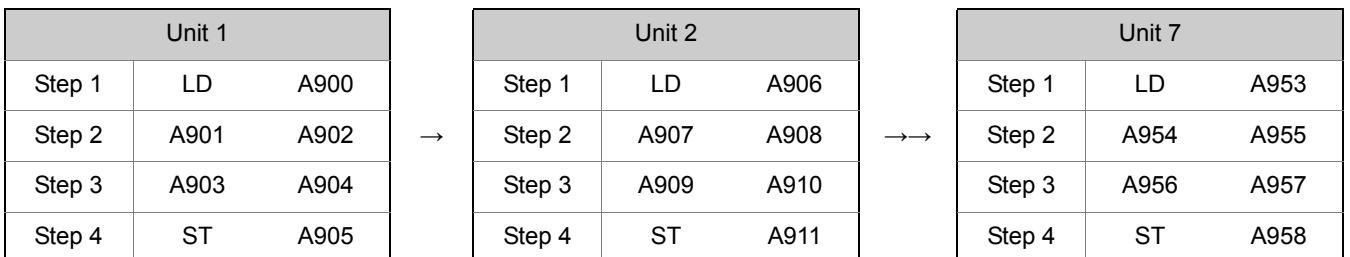

Fig. 4-1 My function block diagram

Table 4-1 Table of My function parameters

		Title	Parameter name	Adjustment range	Default setting
Unit 1	Step 1 (Target)	A900	Input function command target 011	0: Disabled 1: Terminal F 2: Terminal R 3: Terminal RES 4: Terminal S1 5: Terminal S2 6: Terminal S3 7: Terminal S4 8: Terminal S5 9: Terminal DI11 10: Terminal DI12 11: Terminal DI13 12: Terminal DI14 13: Terminal DI15 14: Terminal DI16 15 to 20: - 21 to 24: Virtual input terminal 1 to 4 25 to 32: Internal terminal 1 to 8 918 to 934: My function number. 1000 to 1255: Output select number (Note 1) 2000 to 2099: FD00 - FD99 (Note 2) 3000 to 3099: FE00 - FE99 (Note 2) 4000 to 4099: FA00 - FA99 (Note 2)	0
	Step 2 (Command)	A901	Input function command 012	0: NOP (no operation) 1: ST (store) 2: STN (store inverse) 3: AND (logical product $A \cap B$ ) 4: ANDN (logical product inverse $A \cap \bar{B}$ ) 5: OR (logical sum $A \cup B$ ) 6: ORN (logical sum inverse $A \cup \bar{B}$ ) 7: EQ (equal) 8: NE (not equal) 9: GT ( $A > B$ ) 10: GE ( $A \geq B$ ) 11: LT ( $A < B$ ) 12: LE ( $A \leq B$ ) 13: ASUB (absolute) 14: ON (on delay timer) 15: OFF (off delay timer) 16: COUNT1 (counter 1) 17: COUNT2 (counter 2) 18: HOLD (hold) 19: SET (set) 20: RESET (reset) 21: CLR (clear) 22: CLRN (clear inverse) 23: ON2 (on delay timer 2) 24: OFF2 (off delay timer 2) 25: COUNT3 (counter 3) 26: COUNT4 (counter 4) 27: COUNT5 (counter 5) 28: LD (load)	0

		Title	Parameter name	Adjustment range	Default setting
Unit 1	Step 2 (Command)	A901	Input function command 012	29: LDN(load inverse) 30: ADD(adding) (Note 3) 31: SUB(subtraction) (Note 3) 32: MUL(multiplication) (Note 3) 33: DIV(division) (Note 3) 34: AVE(average) (Note 3) 35: ETU(edge trigger up) (Note 3) 36: ETD(edge trigger down) (Note 3)	0
	Step 2 (Target)	A902	Input function command target 012	Same as A900	0
	Step 3 (Command)	A903	Input function command 013	Same as A901	0
	Step 3 (Target)	A904	Input function command target 013	Same as A900	0
	Step 4 (Output to)	A905	Output function setting destination 1	Same as A900	0
Unit 2	Step 1 (Target)	A906	Input function command target 021	Same as A900	0
	Step 2 (Commands)	A907	Input function command 022	Same as A901	0
	Step 2 (Target)	A908	Input function command target 022	Same as A900	0
	Step 3 (Commands)	A909	Input function command 023	Same as A901	0
	Step 3 (Target)	A910	Input function command target 023	Same as A900	0
	Step 4 (Output to)	A911	Output function setting destination 2	Same as A900	0
Unit 3	Step 1 (Target)	A912	Input function command target 31	Same as A900	0
	Step 2 (Commands)	A913	Input function command 032	Same as A901	0
	Step 2 (Target)	A914	Input function command target 032	Same as A900	0
	Step 3 (Commands)	A915	Input function command 033	Same as A901	0
	Step 3 (Target)	A916	Input function command target 033	Same as A900	0
	Step 4 (Output to)	A917	Output function setting destination 3	Same as A900	0

		Title	Parameter name	Adjustment range	Default setting
Unit 4	Step 1 (Target)	A935	Input function command target 041	Same as A900	0
	Step 2 (Commands)	A936	Input function command 042	Same as A901	0
	Step 2 (Target)	A937	Input function command target 042	Same as A900	0
	Step 3 (Commands)	A938	Input function command 043	Same as A901	0
	Step 3 (Target)	A939	Input function command target 043	Same as A900	0
	Step 4 (Output to)	A940	Output function setting destination 4	Same as A900	0
Unit 5	Step 1 (Target)	A941	Input function command target 051	Same as A900	0
	Step 2 (Commands)	A942	Input function command 052	Same as A901	0
	Step 2 (Target)	A943	Input function command target 052	Same as A900	0
	Step 3 (Commands)	A944	Input function command 053	Same as A901	0
	Step 3 (Target)	A945	Input function command target 053	Same as A900	0
	Step 4 (Output to)	A946	Output function setting destination 5	Same as A900	0
Unit 6	Step 1 (Target)	A947	Input function command target 061	Same as A900	0
	Step 2 (Commands)	A948	Input function command 062	Same as A901	0
	Step 2 (Target)	A949	Input function command target 062	Same as A900	0
	Step 3 (Commands)	A950	Input function command 063	Same as A901	0
	Step 3 (Target)	A951	Input function command target 063	Same as A900	0
	Step 4 (Output to)	A952	Output function setting destination 6	Same as A900	0

		Title	Parameter name	Adjustment range	Default setting
Unit 7	Step 1 (Target)	A953	Input function command target 071	Same as A900	0
	Step 2 (Commands)	A954	Input function command 072	Same as A901	0
	Step 2 (Target)	A955	Input function command target 072	Same as A900	0
	Step 3 (Commands)	A956	Input function command 073	Same as A901	0
	Step 3 (Target)	A957	Input function command target 073	Same as A900	0
	Step 4 (Output to)	A958	Output function setting destination 7	Same as A900	0

Note 1: See Table 8-6 "Output terminal functions" in Appendix 4.

Note 2: See Table 8-7 "Data that My function can handle" in Appendix 5.

Note 3: Available soon

The four kinds of data in the table below, percentage, frequency, time (second), and the number of times can be compared and computed, and they are specified with parameters for the command target to which commands are issued.

Title	Parameter name	Adjustment range	Default setting
A918	Output percent data 1	0.00 - 200.0 (%)	0.00
A919	Output percent data 2	0.00 - 200.0 (%)	0.00
A920	Output percent data 3	0.00 - 200.0 (%)	0.00
A921	Output percent data 4	0.00 - 200.0 (%)	0.00
A922	Output percent data 5	0.00 - 200.0 (%)	0.00
A923	Output frequency data 1	0.0 - 590.0 (Hz)	0.0
A924	Output frequency data 2	0.0 - 590.0 (Hz)	0.0
A925	Output frequency data 3	0.0 - 590.0 (Hz)	0.0
A926	Output frequency data 4	0.0 - 590.0 (Hz)	0.0
A927	Output frequency data 5	0.0 - 590.0 (Hz)	0.0
A928	Output time data 1	0.01 - 600.0 (s)	0.01
A929	Output time data 2	0.01 - 600.0 (s)	0.01
A930	Output time data 3	0.01 - 600.0 (s)	0.01
A931	Output time data 4	0.01 - 600.0 (s)	0.01
A932	Output time data 5	0.01 - 600.0 (s)	0.01
A933	Output number data 1	0 - 9999 (times)	0
A934	Output number data 2	0 - 9999 (times)	0

The table below lists the four virtual input terminals available.

Title	Parameter name	Adjustment range (Note 1)	Default setting
A973	Virtual input terminal select 1	0 - 203	0
A974	Virtual input terminal select 2	0 - 203	0
A975	Virtual input terminal select 3	0 - 203	0
A976	Virtual input terminal select 4	0 - 203	0

Note 1: See Table 8-4 "Input terminal functions" in Appendix 3.

## ■ Enable or disable state of My function

You can set "Enabled" or "Disabled" state of My function

**When you set the My function parameters, be sure to set [A977]="0: Disabled" to prevent the system from starting accidentally.**

After setting the My function parameters, change [A977]="1: Enabled by permission signal" or "2: Always active" to make My function ready to be enabled. (When you set [A977]="1", My function is enabled when a permission signal is issued.)

**Note:** It takes a maximum of 0.5 second for a change of the My function parameters to be reflected internally. Keep standby state at least 0.5 second after setting the parameters.

Title	Parameter name	Adjustment range	Default setting
A977	My function	0: Disabled 1: Enabled by permission signal 2: Always active	0

### 0: Disabled

My function is disabled.

### 1: Enabled by permission signal

My function is in standby state.

When you put input signal into the input terminal assigned functions "64: My function start", My function is enabled.

### 2: Always active

My function is enabled when the inverter is turned on.

**Note:** You cannot change the parameter [A977] during run.

- **In case that My function is disabled**

My function settings are disabled.

When the input terminals are turned on, the inverter operates by the input terminal function.

- **In case that My function is in a standby state**

All signals except the followings are recognized as OFF signals inside of the inverter.

1. My function start
2. Emergency off and Reset

**Note:** Don't use the input terminals assigned the above functions in My function. Or My function start, the emergency off, etc might not activate normally.

- **In case that My function is enabled**

When the input terminals are turned on, the inverter operates by My function.

## 5. Examples of setting

This chapter gives some examples of setting.

Note that the settings described below are examples and there are other ways to set a function for some examples. The following examples of setting use the parameters [A900] to [A982].

When you use the parameters [A800] to [A847], you need to set LD command for beginning and set ST command for end.

- **Examples of the setting of the combined terminal function**

**Example 1:** Performing 2 functions by 1 terminal.

Standby signal is connected with Terminal [F] (Forward run command). (F+ST)

Standby signal is connected with Terminal [R] (Reverse run command). (R+ST)

**Example 2:** Performing 2 functions by 1 terminal.

Performing standby and forward run command by the Terminal [S1]. (ST+F)

**Example 3:** Performing 3 functions by 1 terminal.

Performing standby, forward run command, and preset speed command 1 by the Terminal [S1]. (ST+F+SS1)

**Example 4:** Output signal by logical product of 2 functions.

Output the signal on the condition of detecting both a low-speed signal and an undercurrent signal from the Terminal [R1].

- **Examples of the setting of the relay sequence function**

**Example 5:** Operation with a combination of 2 input signals

Forward run: Either input terminal is turned on.

Reverse run: Both input terminals are turned on.

Stop: Both input terminals are turned off.

**Example 6:** Operation with push type switch.

**Example 7:** Automatic stop by some conditions.

Automatically stop on the condition of 5Hz or less of output frequency and 120% or more of output current.



■ Examples of the setting of the combined terminal function

**Example 1:** Performing 2 functions by 1 terminal  
 Standby signal is connected with Terminal [F] (Forward run command). (F+ST)  
 Standby signal is connected with Terminal [R] (Reverse run command). (R+ST)

See Fig 5-1 for connection diagram and Fig.5-2 for block diagram.  
 Assign the forward run command (F) to the Terminal [F] and reverse run command (R) to the Terminal [R]. (Default setting)  
 Assign the standby (ST) to virtual input terminal.  
 When the Terminal [F] or [R] is turned on, the virtual terminal is turned on automatically.  
 F or R +ST functions are performed.

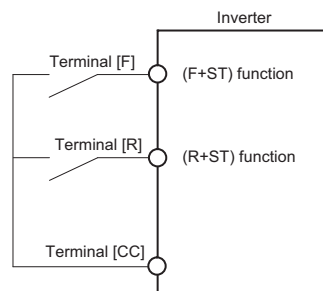

Fig. 5-1 Connection diagram for Example 1

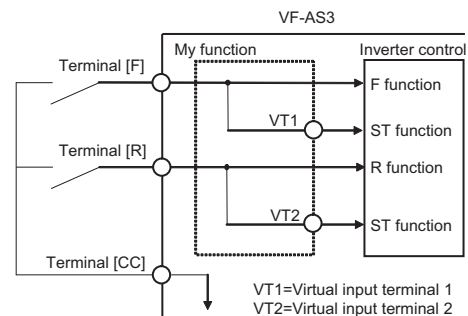

Fig. 5-2 Block diagram for Example 1

Parameter setting

		Title	Parameter setting	Description
Prior setting		A977	0 (Default)	Set to "0: Disabled" of My function.
		F111	2 (Default)	Assign the "2: Fwd run" to the Terminal [F].
		F112	4 (Default)	Assign the "4: Rev run" the Terminal [R].
		A973	6	Assign the "6: Standby" to the virtual input terminal 1.
		A974	6	Assign the "6: Standby" to the virtual input terminal 2.
Unit 1	Step 1	A900	1	Load the Terminal [F] input signal (LD F).
	Step 2	A901	0 (Default)	NOP command (no operation)
		A902	0 (Default)	
	Step 3	A903	0 (Default)	NOP command (no operation)
		A904	0 (Default)	
Step 4	A905	21	Store the result to the virtual input terminal 1.	
Unit 2	Step 1	A906	2	Load the Terminal [R] input signal (LD R).
	Step 2	A907	0 (Default)	NOP command (no operation)
		A908	0 (Default)	
	Step 3	A909	0 (Default)	NOP command (no operation)
		A910	0 (Default)	
Step 4	A911	22	Store the result to the virtual input terminal 2.	
-	-	A977	2	Set to "2: Always active" of My function.

**Example 2:** Performing 2 functions by 1 terminal  
 Performing standby and forward run command by the Terminal [S1]. (ST+F)

See Fig 5-3 for connection diagram and Fig.5-4 for block diagram.  
 Assign the standby (ST) to the Terminal [S1].  
 Assign the forward run command (F) to virtual input terminal 1.  
 When the Terminal [S1] is turned on, the virtual terminal is turned on automatically.  
 ST+F functions are performed.

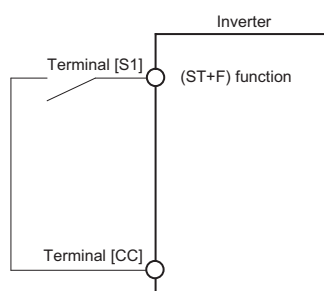

Fig. 5-3 Connection diagram for Example 2

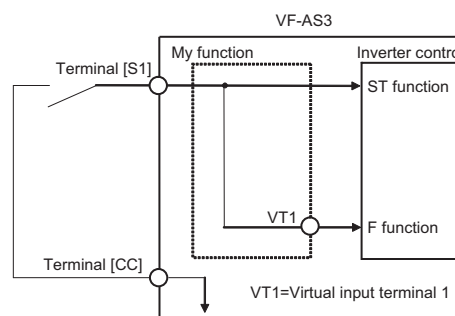

Fig. 5-4 Block diagram for Example 2

Parameter setting

		Title	Parameter setting	Description
Prior setting	-	A977	0 (Default)	Set to "0: Disabled" of My function.
		F114	6	Assign the "6: Standby" to the Terminal [S1].
		A973	2	Assign the "2: Fwd run" to the virtual input terminal 1.
Unit 1	Step 1	A900	4	Load the Terminal [S1] input signal (LD S1).
	Step 2	A901	0 (Default)	NOP command (no operation)
		A902	0 (Default)	
	Step 3	A903	0 (Default)	NOP command (no operation)
		A904	0 (Default)	
Step 4	A905	21	Store the result to the virtual input terminal 1.	
-	-	A977	2	Set to "2: Always active" of My function.

**Example 3:** Performing 3 functions by 1 terminal  
 Performing standby, forward run command and preset speed switching 1 by the Terminal [S1]. (ST+F+SS1)

See Fig 5-5 for connection diagram and Fig.5-6 for block diagram.

Assign the standby (ST) to Terminal [S1].

Assign the forward run command (F) to virtual input terminal 1.

Assign the preset speed switching 1 (SS1) to virtual input terminal 2.

When the Terminal [S1] is turned on, the virtual terminals are turned on automatically.

ST+F+SS1 functions are performed.

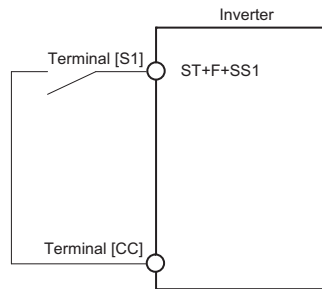

Fig. 5-5 Connection diagram for Example 3

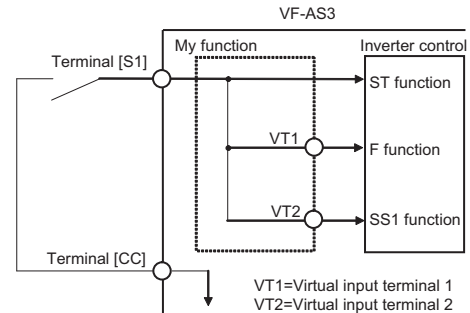

Fig. 5-6 Block diagram for Example 3

Parameter setting

		Title	Parameter setting	Description
Prior setting	-	A977	0 (Default)	Set to "0: Disabled" of My function.
		F114	6	Assign the "6: Standby" to the Terminal [S1].
		A973	2	Assign the "2: Fwd run" to the virtual input terminal 1.
		A974	10	Assign the "10: Preset speed switching 1" to the virtual input terminal 2.
Unit 1	Step 1	A900	4	Load the Terminal [S1] input signal (LD S1).
	Step 2	A901	1	Transfer command
		A902	21	Transfer the result to the virtual input terminal 1.
	Step 3	A903	0 (Default)	NOP command (no operation)
		A904	0 (Default)	
Step 4	A905	22	Store the result to the virtual input terminal 2.	
-	-	A977	2	Set to "2: Always active" of My function.

**Example 4:** Output signal by logical product of 2 functions  
 Output the signal on the condition of detecting both a low-speed signal and an undercurrent alarm from the Terminal [R1].

See Fig 5-7 for block diagram.

Compute by logical product (AND) of a low-speed signal and an Undercurrent alarm.

Transfer the result to the My function output1, and output signal from the Terminal [R1].

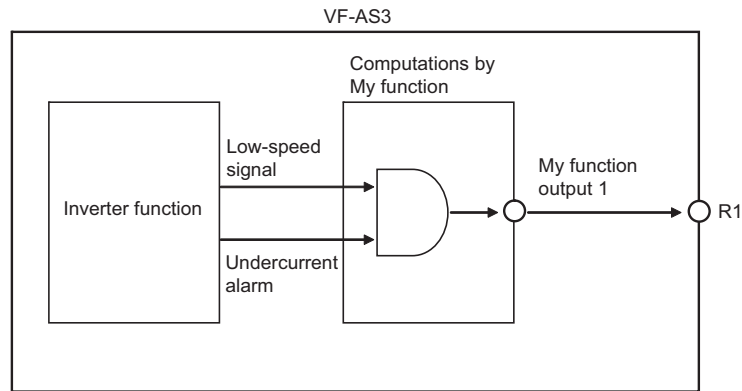

Fig. 5-7 Block diagram for Example 4

Parameter setting

		Title	Parameter setting	Description
Prior setting	-	A977	0 (Default)	Set to "0: Disabled" of My function.
		F113	222	Assign the My function output 1 to the Terminal [R1].
Unit 1	Step 1	A900	1004	Load the low-speed signal (LD LOW)
	Step 2	A901	3	AND command
		A902	1026	The logical product of low-speed signal and undercurrent alarm.
	Step 3	A903	0 (Default)	NOP command (no operation)
		A904	0 (Default)	
Step 4	A905	1222	Store the logical product to the My function output 1.	
-	-	A977	2	Set to "2: Always active" of My function.

■ **Examples of the setting of the relay sequence function**

This section gives an explanation of the relay sequence function using ladder diagrams.

One unit consists of maximum 4 steps when you use the parameters [A900] to [A982]. When your sequence consists of 5 steps or more, you need to change the composition to 4 steps or less.

(You don't need to change the composition to 4 steps or less when you use the [A800] to [A847].)

- Example 5:** Operation with a combination of 2 input signals  
 Input terminals are used as ON/OFF signal like a PLC in this example.  
 Forward run: Either input terminal is turned on.  
 Reverse run: Both input terminals are turned on.  
 Stop: Both input terminals are turned off.

See Fig 5-8 for connection diagram and timing chart.

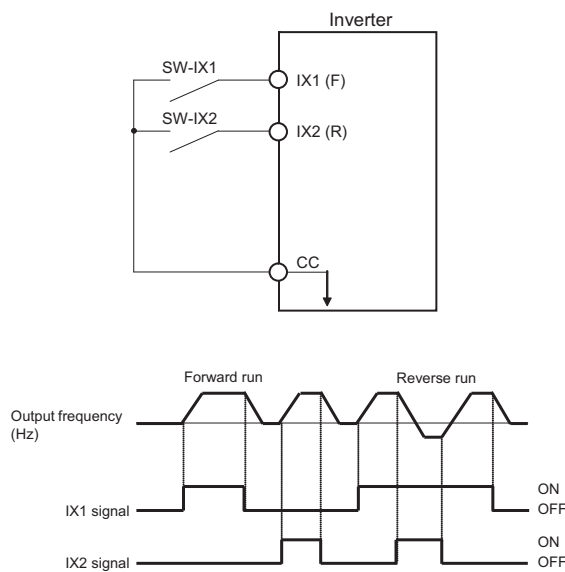
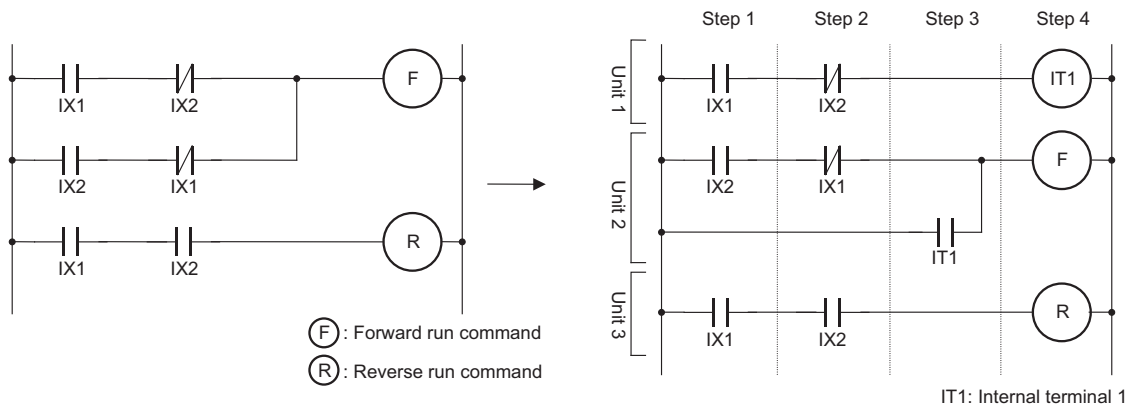

Fig. 5-8 Connection diagram and timing chart for Example 5

Following is the ladder diagram.

The left is general sequence. The sequence of forward run command consists of 5 steps.

You need to change the composition to 4 steps as the right for My function ([A900] to [A982]).



Parameter setting

		Title	Parameter setting	Description
Prior setting	-	A977	0 (Default)	Set to "0: Disabled" of My function.
		F111	0	Assign the "no function" to the Terminal [F]. Use the Terminal [F] as a simple input terminal (IX1).
		F112	0	Assign the "no function" to the Terminal [R]. Use the Terminal [R] as a simple input terminal (IX1).
		A973	2	Assign the forward run command to the virtual input terminal 1 (VT1).
		A974	4	Assign the reverse run command to the virtual input terminal 2 (VT2).
Unit 1	Step 1	A900	1	Load the IX1 (F) terminal input signal. (LD IX1)
	Step 2	A901	4	ANDN command ( $IX1 \cap \overline{IX2}$ )
		A902	2	
	Step 3	A903	0 (Default)	NOP command (no operation)
		A904	0 (Default)	
Step 4	A905	25	Store the result to the internal terminal 1. ( $IX1 \cap \overline{IX2} \rightarrow IT1$ )	
Unit 2	Step 1	A906	2	Load the IX2 (R) terminal input signal. (LD IX2)
	Step 2	A907	4	ANDN command ( $IX2 \cap \overline{IX1}$ )
		A908	1	
	Step 3	A909	5	OR command ( $(IX2 \cap \overline{IX1}) \cup IT1$ )
		A910	25	
Step 4	A911	21	Store the result to the virtual input terminal 1. ( $(IX2 \cap \overline{IX1}) \cup IT1 \rightarrow VT1$ )	
Unit 3	Step 1	A912	1	Load IX1 (F) terminal input signal. (LD IX1)
	Step 2	A913	3	AND command ( $IX1 \cap IX2$ )
		A914	2	
	Step 3	A915	0 (Default)	NOP command (no operation)
		A916	0 (Default)	
Step 4	A917	22	Store the result to the virtual input terminal 2. ( $IX2 \cap IX1 \rightarrow VT2$ )	
-	-	A977	2	Set to "2: Always active" of My function.

NE (not equal) command enables to combine the steps of unit 1 and 2.  
 When the signal of input terminal 1 and 2 are not equal, forward run command is valid.

		Title	Parameter setting	Description
Unit 1	Step 1	A900	1	Load the IX1 (F) terminal input signal. (LD IX1)
	Step 2	A901	8	NE command ( $(IX1 \cap \overline{IX2}) \cup (\overline{IX1} \cap IX2)$ )
		A902	2	
	Step 3	A903	0 (Default)	NOP command (no operation)
		A904	0 (Default)	
Step 4	A905	21	Store the result to the virtual input terminal 1. $(IX1 \cap \overline{IX2}) \cup (\overline{IX1} \cap IX2) \rightarrow VT1$	

**Example 6:** Operation with push type switch  
 Start and stop by push type (non self-hold type) switches.  
 Start with the forward run command (reverse run command), and stop with the stop command.

See Fig 5-9 for connection diagram and timing chart.

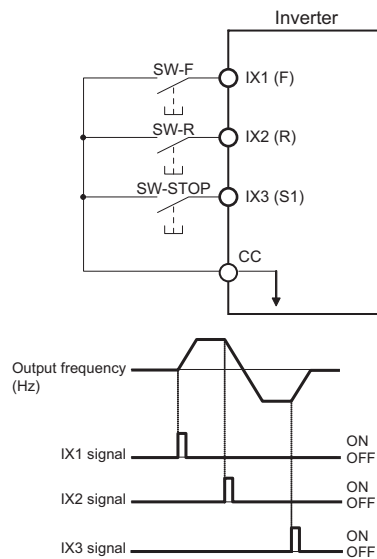

Fig. 5-9 Connection diagram and timing chart for Example 6

Construct self-hold circuit for each forward run command and reverse run command.  
 Break the self-hold by the other command or a stop command.

Following is the ladder diagram.

The left is general sequence of self-hold circuit. Each unit consists of 5 steps.

You need to change the unit A and B to two units each and make composition of 4 steps according to My function ([A900] to [A982]).

(You don't need to change the composition to 4 steps or less when you use the [A800] to [A847].)

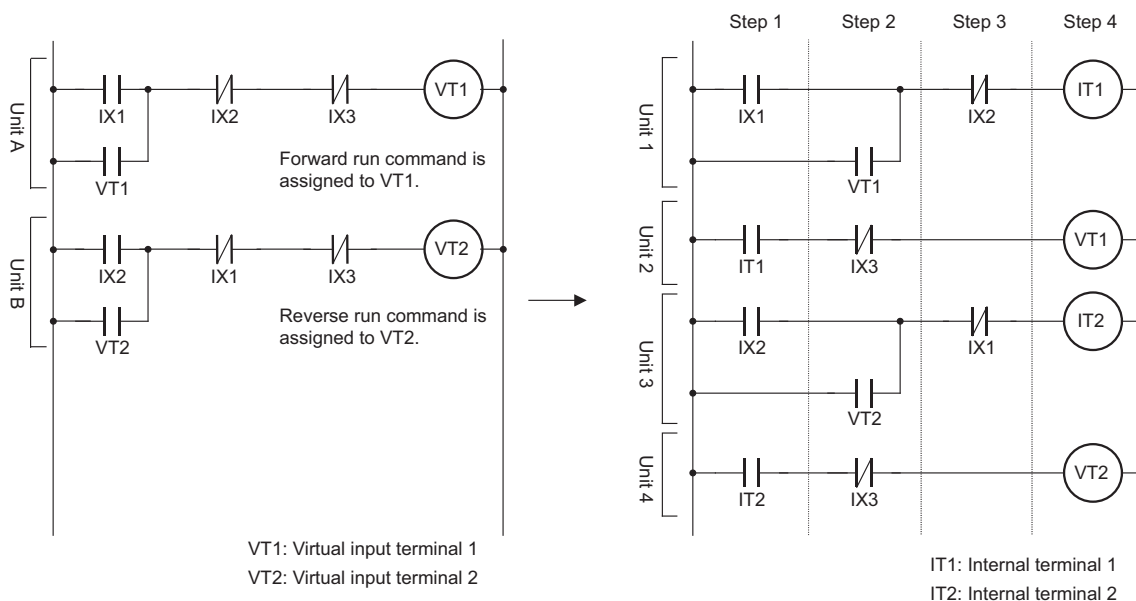

Parameter setting

		Title	Parameter setting	Description
Prior setting	-	A977	0 (Default)	Set to "0: Disabled" of My function.
		F111	0	Assign the "no function" to the Terminal [F]. Use the Terminal [F] as a simple input terminal (IX1).
		F112	0	Assign the "no function" to the Terminal [R]. Use the Terminal [R] as a simple input terminal (IX2).
		F114	0	Assign the "no function" to the Terminal [S1]. Use the Terminal [S1] as a simple input terminal (IX3).
		A973	2	Assign the forward run command to the virtual input terminal 1 (VT1)
		A974	4	Assign the reverse run command to the virtual input terminal 2 (VT2)
Unit 1	Step 1	A900	1	Load the IX1 (F) terminal input signal. (LD IX1)
	Step 2	A901	5	OR command ( $IX1 \cup VT1$ ) self-hold circuit
		A902	21	
	Step 3	A903	4	ANDN command ( $IX1 \cup VT1 \cap \overline{IX2}$ )
		A904	2	
Step 4	A905	25	Store the result to the internal terminal 1 ( $IX1 \cup VT1 \cap \overline{IX2} \rightarrow IT1$ )	
Unit 2	Step 1	A906	25	Load the IT1 (Internal terminal 1) signal (LD IT1).
	Step 2	A907	4	ANDN command ( $IT1 \cap \overline{IX3}$ )
		A908	4	
	Step 3	A909	0 (Default)	NOP command (no operation)
		A910	0 (Default)	
	Step 4	A911	21	Store the result to the virtual input terminal 1 (VT1) ( $IT1 \cap \overline{IX3} \rightarrow VT1$ )



		Title	Parameter setting	Description
Unit 3	Step 1	A912	2	Load the IX2(R) terminal input signal. (LD IX2)
	Step 2	A913	5	OR command ( $IX2 \cup VT2$ ) self-hold circuit
		A914	22	
	Step 3	A915	4	ANDN command ( $IX2 \cup VT2 \cap \overline{IX1}$ )
		A916	1	
Step 4	A917	26	Store the result to the internal terminal 2 (IT2) ( $IX2 \cup VT2 \cap \overline{IX1} \rightarrow IT2$ )	
Unit 4	Step 1	A935	26	Load the IT2 (Internal terminal 2) signal (LD IT2)
	Step 2	A936	4	ANDN command ( $IT2 \cap \overline{IX3}$ )
		A937	4	
	Step 3	A938	0 (Default)	NOP command (no operation)
		A939	0 (Default)	
Step 4	A940	22	Store the result to the virtual input terminal 2 (VT2) ( $IT2 \cap \overline{IX3} \rightarrow VT2$ )	
–	–	A977	2	Set to “2: Always active” of My function.

**Example 7:** Automatic stop by some conditions  
 Automatically stop on the condition of 5Hz or less of output frequency and 120% or more of output current.  
 Start by push type (non self-hold type) switch.

See Fig 5-10 for connection diagram and timing chart.

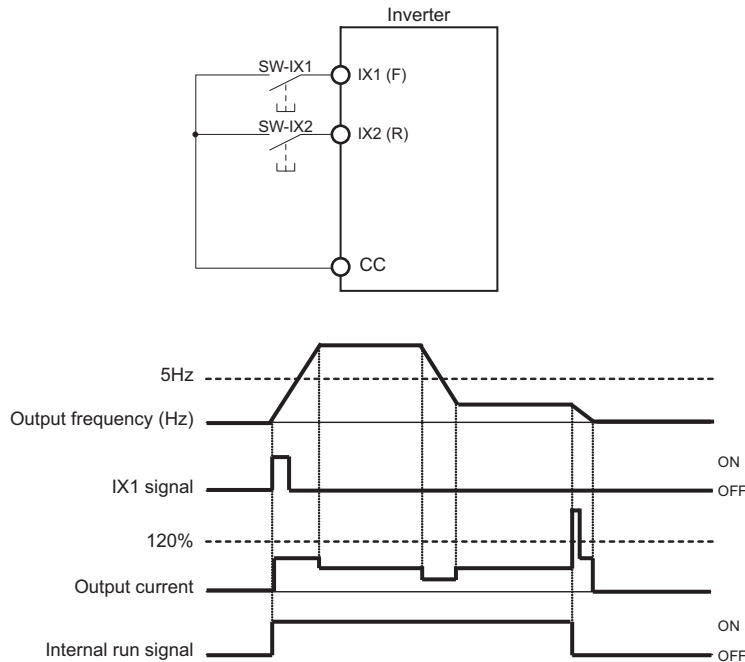

Fig. 5-10 Connection diagram and timing chart for Example 7

- Terminal [F] is used as forward command with push type (non self-hold type) switch.
- Break the forward run command in case that the output frequency is 5Hz or less and the output current is 120% or more of the rated current.
- Forced stop by input signal from Terminal [S1] (by breaking forward run command).

The following is the ladder diagram.

The left is general sequence of self-hold circuit. Unit A consists of 5 steps.

You need to change the unit to two units, and make the composition of 4 steps according to My function ([A900] to [A982]).

(You don't need to change the composition to 4 steps or less when you use the [A800] to [A847].)

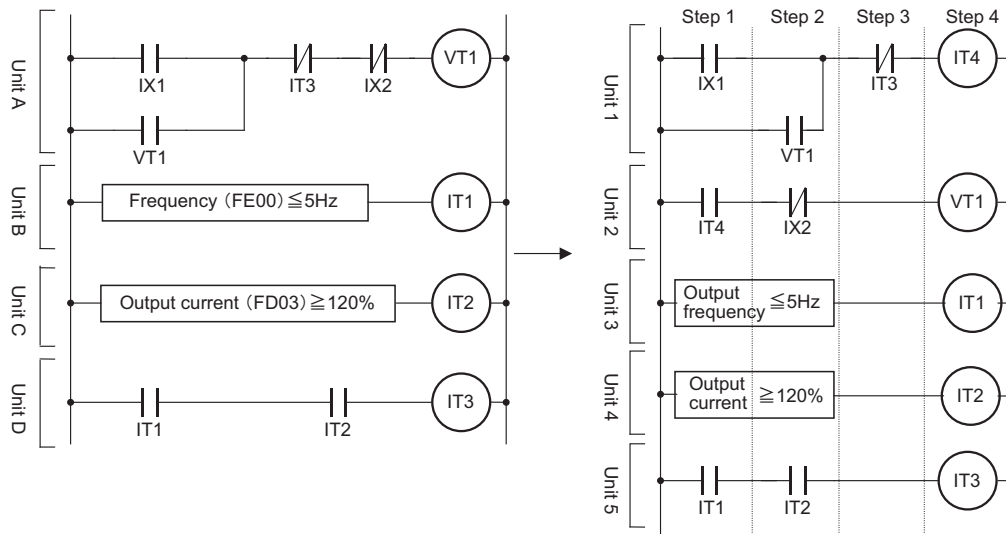

VT1: Virtual input terminal (forward run command)  
 IT1: Internal terminal 1  
 IT2: Internal terminal 2  
 IT3: Internal terminal 3  
 IT4: Internal terminal 4

Parameter setting

		Title	Parameter setting	Description
Prior setting	-	A977	0 (Default)	Set to "0: Disabled" of My function.
		F111	0	Assign the "no function" to the Terminal [F]. Use the Terminal [F] as a simple input terminal (IX1).
		F114	0	Assign the "no function" to the Terminal [S1]. Use the Terminal [S1] as a simple input terminal (IX2).
		A918	120	Set the limit at 120% to use it as a reference value when comparing and computing currents.
		A923	5	Set the limit at 5Hz to use it as a reference value when comparing and computing frequencies.
		A973	2	Assign the forward run command to the virtual input terminal 1 (VT1)
Unit 1	Step 1	A900	1	Load the IX1(F) terminal input signal (LD IX1)
	Step 2	A901	5	OR command ( IX1 ∪ VT1 )
		A902	21	
	Step 3	A903	4	ANDN command ( IX1 ∪ VT1 ∩ IT3̄ )
		A904	27	
Step 4	A905	28	Store the result to the internal terminal 4 (IT4) ( IX1 ∪ VT1 ∩ IT3̄ → IT4 )	

		Title	Parameter setting	Description
Unit 2	Step 1	A906	28	Load the IT4 (Internal terminal 4) signal (LD IT4)
	Step 2	A907	4	ANDN command ( $IT4 \cap \overline{IX2}$ )
		A908	4	
	Step 3	A909	0 (Default)	NOP command (no operation)
		A910	0 (Default)	
Step 4	A911	21	Store the result to the virtual input terminal 1 (VT1). ( $IT4 \cap \overline{IX2} \rightarrow VT1$ )	
Unit 3	Step 1	A912	3000	Load the output frequency (LD Output frequency)
	Step 2	A913	12	LE command (Comparison to 5Hz)
		A914	923	
	Step 3	A915	0 (Default)	NOP command (no operation)
		A916	0 (Default)	
Step 4	A917	25	Store the result to the internal terminal 1 (IT1) (Comparison to 5Hz $\rightarrow$ IT1)	
Unit 4	Step 1	A935	2003	Load the output current (LD Output current)
	Step 2	A936	10	GE command (Comparison to 120%)
		A937	918	
	Step 3	A938	0 (Default)	NOP command (no operation)
		A939	0 (Default)	
Step 4	A940	26	Store the result to the internal terminal 2 (IT2) (Comparison to 120% $\rightarrow$ IT2)	
Unit 5	Step 1	A941	25	Load the IT1 (Internal terminal 1) signal (LD IT1)
	Step 2	A942	3	AND command ( $IT1 \cap IT2$ )
		A943	26	
	Step 3	A944	0 (Default)	NOP command (no operation)
		A945	0 (Default)	
Step 4	A946	27	Store the result to the internal terminal 3 (IT3) ( $IT1 \cap IT2 \rightarrow IT3$ )	
–	–	A977	2	Set to “2: Always active” of My function.

## 6. Analog input My function

The operation panel is usually used to set parameters, but the analog input My function allows specific parameters and functions to be set continuously using an external control device.

The figure below shows setting the upper limit frequency (UL) by analog signals.

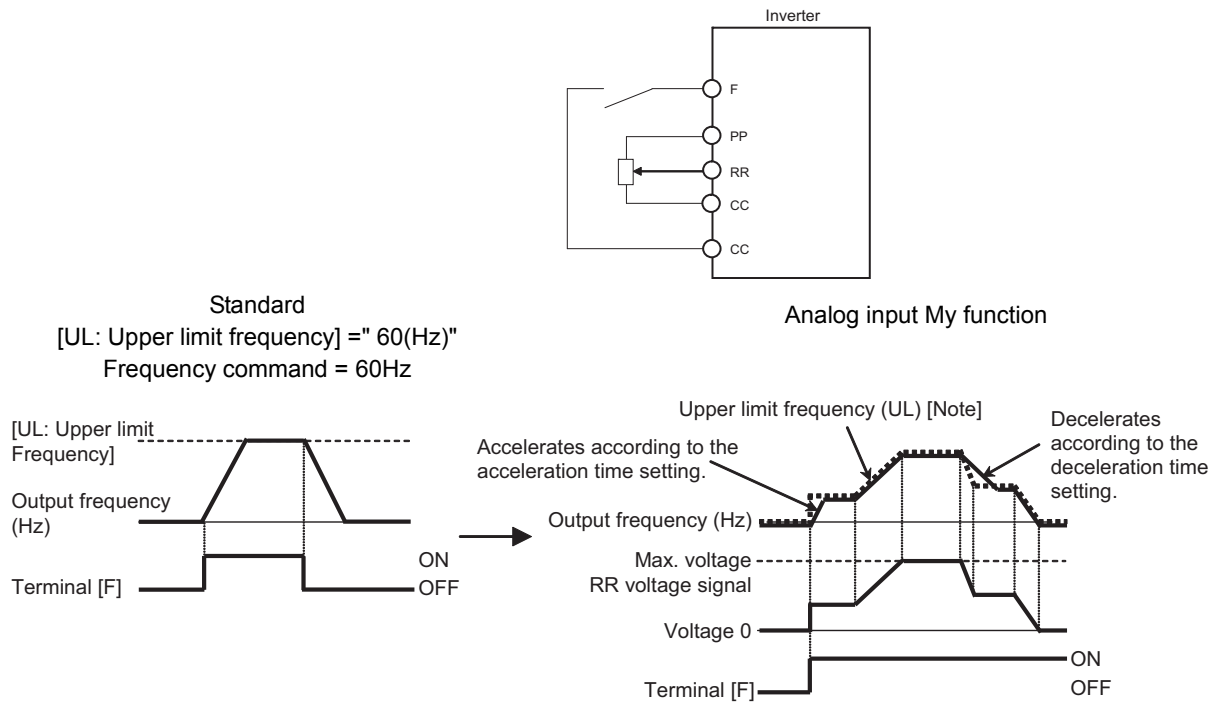

**Note:** Adjustments are made by the inverter itself, so no changes are made to parameter settings.

The acceleration and deceleration time can be adjusted by changing the analog input value of the Terminal [RR]. The analog input My function is applicable to the 11 objects in [A961] and [A964] (Analog function setting destination) of the table below. The terminals to which the analog input My function is assigned can be specified with the parameters [A959] and [A962] (Analog input function target).

## ■ Parameter setting

Title	Parameter name	Adjustment range	Default setting
A959	Analog input function target 11	0: Disabled 1: Terminal RR 2: Terminal RX 3: Terminal II 4: Terminal AI4 5: Terminal AI5	0
A961	Analog function setting destination 11	0: Disabled 1: Acc/Dec rate (ACC, dEC, etc.) 2: Upper limit frequency (UL) 3: Acc multiplication factor (FH/ACC etc.) 4: Dec multiplication factor (FH/dEC etc.) 5: Manual torque boost (vb etc.) 6: Stall prevention level (F601 etc.) 7: Motor OL protection current (tHrA etc.) 8: Speed control response (F460 etc.) 9: Droop gain (F320 etc.) 10: PID proportional gain (F362 etc.) 11: Base frequency voltage (vL etc.)	0
A962	Analog input function target 21	Same as A959	0
A964	Analog function setting destination 21	Same as A961	0

The analog input My function can be set in two ways.

The analog input value specified with [A959] can adjust the object selected with [A961]. [A962] and [A964] are same as [A959] and [A961].

This analog adjustment range can be adjusted by changing input points ([F201] to [F204], [F210] to [F213], and [F216] to [F219]) and the maximum frequency setting.

To be more specific, when the analog input voltage varies from 0 to 10V, the value set with the parameter [A961] changes by a factor of:

$$\frac{F1}{FH} \text{ to } \frac{F2}{FH}$$

FH is the maximum frequency (Hz), F1 is the frequency (Hz) at 0V, and F2 is the frequency (Hz) at 10V.

### 1: Acc/Dec rate

This setting allows the acceleration/deceleration rate to change in proportion to the analog input value.

An example of using the Terminal [RR] is given below.

```
[FH]="80(Hz)"
[A959]="2: Terminal RR"
[A961]="1: Acc/dec rate"
[F210]="0(%)"
[F211]="20(Hz)"
[F212]="100(%)"
[F213]="80(Hz)"
```

$$0V \quad \text{Acc/dec rate} = \frac{20(\text{Hz})}{80(\text{Hz})} = 0.25$$

$$10V \quad \text{Acc/dec rate} = \frac{80(\text{Hz})}{80(\text{Hz})} = 1.00$$

RR input value varies from 0 to the maximum value, the Acc/dec rate changes by a factor of 0.25 to 1.

**Note:** Acc/dec rate: 0.25 means that the time elapsing before the completion of acceleration or deceleration increases by 4 times.

## 2: Upper limit frequency

This setting allows the upper limit frequency (UL) to change in proportion to the analog input value.

The settings to be made are the same as "1: Acc/dec rate". In this example, when [A961]="2: Upper limit frequency", the upper limit frequency set with [UL] changes by a factor of 0.25 to 1 according to the RR input value (0 to maximum value).

## 3: Acc multiplication factor

The acceleration time is determined by multiplying acceleration time 1 to acceleration time 4 (Acc, F500, F510 and F514) by the factor that varies with the analog input value.

The settings to be made are the same as "1: Acc/dec rate". In this example, when [A961]="3: Acc multiplication factor", acceleration time 1 to acceleration time 4 set with [ACC], [F500], [F510] and [F514] change by a factor of 0.25 to 1 according to the RR input value (0 to maximum value).

## 4: Dec multiplication factor

The deceleration multiplication factor has the same function as the acceleration multiplication factor described above. It is used with deceleration time 1 to deceleration time 4 ([Dec], [F501], [F511] and [F515]).

## 5: Manual torque boost

This setting allows the amount of boosted torque ([vb], [F172], [F176] and [F180]) to change in proportion to the analog input value.

The settings to be made are the same as "1: Acc/dec rate". In this example, when [A961]="5: Manual torque boost", the amount of manually boosted torque set with [vb], [F172], [F176] and [F180] changes by a factor of 0.25 to 1 according to the RR input value (0 to maximum value).

## 6: Stall prevention level

This setting allows the stall prevention level ([F601] and [F185]) to change in proportion to the analog input value.

The settings to be made are the same as "1: Acc/dec rate". In this example, when [A961]="6: Stall prevention level", the Stall prevention level set with [F601] and [F185] change by a factor of 0.25 to 1 according to the RR input value (0 to maximum value).

## 7: Motor OL protection current

This setting allows the Motor OL protection current ([tHrA], [F182], [F183] and [F184]) to change in proportion to the analog input value.

The settings to be made are the same as "1: Acc/dec rate". In this example, when [961]="7: Motor OL protection current", the motor OL protection current set with [tHrA], [F182], [F183] and [F184] changes by a factor of 0.25 to 1 according to the RR input value (0 to maximum value).

## 8: Speed control response

This setting allows the Speed control response (F460) to change in proportion to the analog input value.

The settings to be made are the same as "1: Acc/dec rate". In this example, when [A961]="8: Speed control response", the speed control response set with [F460] changes by a factor of 0.25 to 1 according to the RR input value (0 to maximum value).

**9: Droop gain**

This setting allows the droop gain (F320) to change in proportion to the analog input value.

The settings to be made are the same as "1: Acc/dec rate". In this example, when [A961]="9: Droop gain", the droop gain set with [F320] changes by a factor of 0.25 to 1 according to the RR input value (0 to maximum value).

**10: PID proportional gain**

This setting allows the PID proportional gain (F362) to change in proportion to the analog input value.

The settings to be made are the same as "1: Acc/dec rate". In this example, when [A961]="10: PID proportional gain", the PID proportional gain set with [F362] changes by a factor of 0.25 to 1 according to the RR input value (0 to maximum value).

**11: Base frequency voltage**

This setting allows the Base frequency voltage ([vLv], [F171], [F175] and [F179]) to change in proportion to the analog input value.

The settings to be made are the same as "1: Acc/dec rate". In this example, when [A961]="11: Base frequency voltage", the Base frequency voltage set with [vLv], [F171], [F175] and [F179] changes by a factor of 0.25 to 1 according to the RR input value (0 to maximum value).



## 7. Analog output My function

This function outputs a parameter set value monitored, its peak value and minimum value through an analog output terminal. This function lets you know mainly the maximum and minimum values in a given period of time.

### ■ Parameter setting

Title	Parameter name	Adjustment range	Default setting
A965	Monitor output target 11	2000-2099: FD00-FD99 (Note 1) 3000-3099: FE00-FE99 (Note 1) 4000-4099: FA00-FA99 (Note 1)	2000
A966	Monitor output command 11	0: Normal monitor 1: Max. value 2: Min. value	0
A967	Monitor output target 21	Same as A965	2000
A968	Monitor output command 21	Same as A966	0
A969	Monitor output target 31	Same as A965	2000
A970	Monitor output command 31	Same as A966	0
A971	Monitor output target 41	Same as A965	2000
A972	Monitor output command 41	Same as A966	0

Note 1: See Table 8-7 "Data that My function can handle" in Appendix 5.

**Appendix 1 Table of My function parameters**

Table 8-1 Table of My function parameters

Title	Parameter name	Adjustment range	Default setting
A900	Input function command target 011	0: Disabled 1: Terminal F 2: Terminal R 3: Terminal RES 4: Terminal S1 5: Terminal S2 6: Terminal S3 7: Terminal S4 8: Terminal S5 9: Terminal DI11 10: Terminal DI12 11: Terminal DI13 12: Terminal DI14 13: Terminal DI15 14: Terminal DI16 15 to 20: - 21 to 24: Virtual input terminal 1 to 4 25 to 32: Internal terminal 1 to 8 918 to 934: My function number. 1000 to 1255: Output select number (Note 1) 2000 to 2099: FD00 - FD99 (Note 2) 3000 to 3099: FE00 - FE99 (Note 2) 4000 to 4099: FA00 - FA99 (Note 2)	0

Title	Parameter name	Adjustment range	Default setting
A901	Input function command 012	0: NOP (no operation) 1: ST (move) 2: STN (move inverse) 3: AND (logical product ( $A \cap B$ )) 4: ANDN (logical product inverse ( $A \cap \bar{B}$ )) 5: OR (logical sum ( $A \cup B$ )) 6: ORN (logical sum inverse ( $A \cup \bar{B}$ )) 7: EQ (equal) 8: NE (not equal) 9: GT ( $A > B$ ) 10: GE ( $A \geq B$ ) 11: LT ( $A < B$ ) 12: LE ( $A \leq B$ ) 13: ASUB (absolute) 14: ON (on delay timer) 15: OFF (off delay timer) 16: COUNT1 (counter 1) 17: COUNT2 (counter 2) 18: HOLD (hold) 19: SET (set) 20: RESET (reset) 21: CLR (clear) 22: CLRN (clear inverse) 23: ON2 (on delay timer 2) 24: OFF2 (off delay timer 2) 25: COUNT3 (counter 3) 26: COUNT4 (counter 4) 27: COUNT5 (counter 5) 28: LD (Load) 29: LDN (Load inverse) 30: ADD (adding) (Note 3) 31: SUB (subtraction) (Note 3) 32: MUL (multiplication) (Note 3) 33: DIV (division) (Note 3) 34: AVE (average) (Note 3) 35: ETU (Edge trigger up) (Note 3) 36: ETD (Edge trigger down) (Note 3)	0
A902	Input function command target 012	Same as A900	0
A903	Input function command 013	Same as A901	0
A904	Input function command target 013	Same as A900	0
A905	Output function setting destination 1	Same as A900	0
A906	Input function command target 021	Same as A900	0
A907	Input function command 022	Same as A901	0
A908	Input function command target 022	Same as A900	0
A909	Input function command 023	Same as A901	0
A910	Input function command target 023	Same as A900	0
A911	Output function setting destination 2	Same as A900	0
A912	Input function command target 031	Same as A900	0
A913	Input function command 032	Same as A901	0

Title	Parameter name	Adjustment range	Default setting
A914	Input function command target 032	Same as A900	0
A915	Input function command 033	Same as A901	0
A916	Input function command target 033	Same as A900	0
A917	Output function setting destination 3	Same as A900	0

Note 1: See Table 8-6 “Output terminal functions” in Appendix 4.

Note 2: See Table 8-7 “Data that My function can handle” in Appendix 5.

Note 3: Available soon

Title	Parameter name	Adjustment range	Default setting
A918	Output percent data 1	0.00-200.0 %	0.00
A919	Output percent data 2	0.00-200.0 %	0.00
A920	Output percent data 3	0.00-200.0 %	0.00
A921	Output percent data 4	0.00-200.0 %	0.00
A922	Output percent data 5	0.00-200.0 %	0.00
A923	Output frequency data 1	0.0-590.0 Hz	0.0
A924	Output frequency data 2	0.0-590.0 Hz	0.0
A925	Output frequency data 3	0.0-590.0 Hz	0.0
A926	Output frequency data 4	0.0-590.0 Hz	0.0
A927	Output frequency data 5	0.0-590.0 Hz	0.0
A928	Output time data 1	0.01-600.0 s	0.01
A929	Output time data 2	0.01-600.0 s	0.01
A930	Output time data 3	0.01-600.0 s	0.01
A931	Output time data 4	0.01-600.0 s	0.01
A932	Output time data 5	0.01-600.0 s	0.01
A933	Output number data 1	0-9999 times	0
A934	Output number data 2	0-9999 times	0
A935	Input function command target 041	Same as A900	0
A936	Input function command 042	Same as A901	0
A937	Input function command target 042	Same as A900	0
A938	Input function command 043	Same as A901	0
A939	Input function command target 043	Same as A900	0
A940	Output function setting destination 4	Same as A900	0
A941	Input function command target 051	Same as A900	0
A942	Input function command 052	Same as A901	0
A943	Input function command target 052	Same as A900	0
A944	Input function command 053	Same as A901	0
A945	Input function command target 053	Same as A900	0
A946	Output function setting destination 5	Same as A900	0

Title	Parameter name	Adjustment range	Default setting
A947	Input function command target 061	Same as A900	0
A948	Input function command 062	Same as A901	0
A949	Input function command target 062	Same as A900	0
A950	Input function command 063	Same as A901	0
A951	Input function command target 063	Same as A900	0
A952	Output function setting destination 6	Same as A900	0
A953	Input function command target 071	Same as A900	0
A954	Input function command 072	Same as A901	0
A955	Input function command target 072	Same as A900	0
A956	Input function command 073	Same as A901	0
A957	Input function command target 073	Same as A900	0
A958	Output function setting destination 7	Same as A900	0
A973	Virtual input terminal select 1	0- 203 (Note4)	0
A974	Virtual input terminal select 2	0- 203 (Note4)	0
A975	Virtual input terminal select 3	0- 203 (Note4)	0
A976	Virtual input terminal select 4	0- 203 (Note4)	0
A977	My function	0: Disabled 1: Enabled by permission signal 2: Always active	0

Note 4: See Table 8-4 "Input terminal functions" in Appendix 3.

Title	Parameter name	Adjustment range	Default setting
A800	Input function command 081	Same as A901	0
A801	Input function command target 081	Same as A900	0
A802	Input function command 082	Same as A901	0
A803	Input function command target 082	Same as A900	0
A804	Input function command 083	Same as A901	0
A805	Input function command target 083	Same as A900	0
A806	Input function command 084	Same as A901	0
A807	Input function command target 084	Same as A900	0
A808	Input function command 091	Same as A901	0
A809	Input function command target 091	Same as A900	0
A810	Input function command 092	Same as A901	0
A811	Input function command target 092	Same as A900	0
A812	Input function command 093	Same as A901	0
A813	Input function command target 093	Same as A900	0
A814	Input function command 094	Same as A901	0

Title	Parameter name	Adjustment range	Default setting
A815	Input function command target 094	Same as A900	0
A816	Input function command 101	Same as A901	0
A817	Input function command target 101	Same as A900	0
A818	Input function command 102	Same as A901	0
A819	Input function command target 102	Same as A900	0
A820	Input function command 103	Same as A901	0
A821	Input function command target 103	Same as A900	0
A822	Input function command 104	Same as A901	0
A823	Input function command target 104	Same as A900	0
A824	Input function command 111	Same as A901	0
A825	Input function command target 111	Same as A900	0
A826	Input function command 112	Same as A901	0
A827	Input function command target 112	Same as A900	0
A828	Input function command 113	Same as A901	0
A829	Input function command target 113	Same as A900	0
A830	Input function command 114	Same as A901	0
A831	Input function command target 114	Same as A900	0
A832	Input function command 121	Same as A901	0
A833	Input function command target 121	Same as A900	0
A834	Input function command 122	Same as A901	0
A835	Input function command target 122	Same as A900	0
A836	Input function command 123	Same as A901	0
A837	Input function command target 123	Same as A900	0
A838	Input function command 124	Same as A901	0
A839	Input function command target 124	Same as A900	0
A840	Input function command 131	Same as A901	0
A841	Input function command target 131	Same as A900	0
A842	Input function command 132	Same as A901	0
A843	Input function command target 132	Same as A900	0
A844	Input function command 133	Same as A901	0
A845	Input function command target 133	Same as A900	0
A846	Input function command 134	Same as A901	0
A847	Input function command target 134	Same as A900	0

## Appendix 2 Computing functions

Table 8-2 is the computing functions provided by the My function.

Table 8-2 Computing functions

Input function command	Computation name	Function	Description
0	NOP	No operation	Unnecessary sections (columns) of the My function program.
1	ST	Store	Used mainly to store data.
2	STN	Store (inverse)	Used mainly to invert data and store inverted data.
3	AND	Logical product	Logical product of data ( $A \cap B$ )
4	ANDN	Logical product (inverse of right side)	Logical product of data ( $A \cap \bar{B}$ )
5	OR	Logical sum	Logical sum of data ( $A \cup B$ )
6	ORN	Logical sum (inverse of right side)	Logical sum of data ( $A \cup \bar{B}$ )
7	EQ	Comparison of data for matching	Compare two pieces of data, and output 1 when they match each other or 0 when not.
8	NE	Comparison of data for mismatch	Compare two pieces of data, and output 0 when they match each other or 1 when not.
9	GT	Comparison of sizes ( $A > B$ )	Compare the size of two pieces of data ( $A\_GT\_B$ ), and output 1 when A is over B ( $A > B$ ) or 0 when A is equal to or under B ( $A \leq B$ )
10	GE	Comparison of sizes ( $A \geq B$ )	Compare the size of two pieces of data ( $A\_GT\_B$ ), and output 1 when A is equal to or over B ( $A \geq B$ ) or 0 when A is under B ( $A < B$ )
11	LT	Comparison of sizes ( $A < B$ )	Compare the size of two pieces of data ( $A\_GT\_B$ ), and output 1 when A is under B ( $A < B$ ) or 0 when A is equal to or over B ( $A \geq B$ )
12	LE	Comparison of sizes ( $A \leq B$ )	Compare the size of two pieces of data ( $A\_GT\_B$ ), and output 1 when A is equal to or under B ( $A \leq B$ ) or 0 when A is over B ( $A > B$ )
13	ASUB	Absolute value of difference	Output the absolute value of the difference between two pieces of data. $ A - B $
14 (Note 1)	ON (ON timer)	ON delay	Delays the timing of turning data ON by the time specified with [A928] to [A932]. Output the data simultaneously with turning on the power in case the signal is already on.
15 (Note 1)	OFF (OFF timer)	OFF delay	Delay the timing of turning data OFF by the time specified with [A928] to [A932]. Output the data simultaneously with turning on the power in case the signal is off.
16 (Note 1)	COUNT1	Counter	Count the number of input pulses (count the number of rising edges) and output "1" when reached the pulse count specified with [A933].
17 (Note 1)	COUNT2	Counter	Count the number of input pulses (count the number of rising edges) and output "1" when reached the pulse count specified with [A934].
18 (Note 1)	HOLD	Peak hold	Output the peak input value.

Input function command	Computation name	Function	Description
19 (Note 1)	SET	Set	Set data.
20 (Note 1)	RESET	Reset	Reset data.
21 (Note 1)	CLR	Clear	Clear data.
22 (Note 1)	CLR <sub>N</sub>	Clear (inverse)	Clear data (Inverse).
23	ON <sub>2</sub> (ON timer 2)	ON delay	Delay the timing of turning data on by the time specified with [A928] to [A932]. Delay the timing of data output by specified time in case the signal is on when the power is turned on.
24	OFF <sub>2</sub> (OFF timer 2)	OFF delay	Delay the timing of turning data off by the time specified with [A928] to [A932]. Delay the timing of data output by specified time in case the signal is off when the power is turned on.
25	COUNT <sub>3</sub>	Counter	Count the number of input pulses (count the number of rising edges) and output "1" when reached the pulse count specified with [A980].
26	COUNT <sub>4</sub>	Counter	Count the number of input pulses (count the number of rising edges) and output "1" when reached the pulse count specified with [A981].
27	COUNT <sub>5</sub>	Counter	Count the number of input pulses (count the number of rising edges) and output "1" when reached the pulse count specified with [A982].
28	LD	Load	Used mainly to load data.
29	LD <sub>N</sub>	Load (inverse)	Used mainly to invert data and load inverted data.
30 (Note 2)	ADD	Adding	Adding of data
31 (Note 2)	SUB	Subtraction	Subtraction of data
32 (Note 2)	MUL	Multiplication	Multiplication of data
33 (Note 2)	DIV	Division	Division of data
34 (Note 2)	AVE	Average	Average of data
35 (Note 2)	ETU	Edge trigger up	Output "1" when the input status changes "0" to "1".
36 (Note 2)	ETD	Edge trigger down	Output "1" when the input status changes "1" to "0".

Note 1: For details of computing functions 14 to 27, see Appendix 6.

Note 2: Available soon



### Appendix 3 Input terminal function select parameters

Table 8-3 is the function setting of 18 input terminals (including 6 option terminals and 4 virtual input terminals).  
Table 8-4 is the input terminal functions.

Table 8-3 Input terminal function select parameters

Title	Communication No.	Parameter name	Adjustment range (Note 1)	Default setting
F110	0110	Always active function 1	0-177	6
F127	0127	Always active function 2	0-177	0
F128	0128	Always active function 3	0-177	0
F111	0111	Terminal F function 1	0-203	2
F112	0112	Terminal R function 2	0-203	4
F113	0113	Terminal RES function 1	0-203	8
F114	0114	Terminal S1 function 1	0-203	10
F115	0115	Terminal S2 function	0-203	12
F116	0116	Terminal S3 function	0-203	14
F117	0117	Terminal S4 function	0-203	16
F118	0118	Terminal S5 function	0-203	118
F119	0119	Terminal DI11 function	0-203	0
F120	0120	Terminal DI12 function	0-203	0
F121	0121	Terminal DI13 function	0-203	0
F122	0122	Terminal DI14 function	0-203	0
F123	0123	Terminal DI15 function	0-203	0
F124	0124	Terminal DI16 function	0-203	0
F151	0151	Terminal F function 2	0-203	0
F152	0152	Terminal R function 2	0-203	0
F153	0153	Terminal RES function 2	0-203	0
F154	0154	Terminal S1 function 2	0-203	0
F155	0155	Terminal F function 3	0-203	0
F156	0156	Terminal R function 3	0-203	0
F157	0157	Terminal S1 function 3	0-203	0
A973	A973	Virtual input terminal select 1	0-203	0
A974	A974	Virtual input terminal select 2	0-203	0
A975	A975	Virtual input terminal select 3	0-203	0
A976	A976	Virtual input terminal select 4	0-203	0

Note 1: For an explanation of the adjustment range, see Table 8-4 "Input terminal functions."

Table 8-4 Input terminal functions

Parameter setting		Function	Parameter setting		Function
Positive logic	Negative logic		Positive logic	Negative logic	
0	1	No function	84	85	Terminal R2 output hold
2	3	F: Fwd run	88	89	Terminal Up frequency
4	5	R: Rev run	90	91	Terminal Down frequency
6	7	ST: Standby	92	93	Terminal Up,Down frequency clear
8	9	RES: Reset 1	94	95	Dancer correction OFF
10	11	SS1: Preset speed switching 1	96	97	Coast stop
12	13	SS2: Preset speed switching 2	98	99	Fwd/Rev
14	15	SS3: Preset speed switching 3	100	101	Run/Stop
16	17	SS4: Preset speed switching 4	102	103	Commercial power run switching
18	19	Jog run	104	105	FMOd/F207 priority switching
20	21	Emergency off	106	107	Terminal II priority
22	23	DC braking	108	109	Terminal run priority
24	25	Acc/Dec switching 1	110	111	Parameter writing unlocked
26	27	Acc/Dec switching 2	112	113	Speed control/ Torque control switching
28	29	V/f switching 1	114	115	External equipment counter
30	31	V/f switching 2	116	117	PID 1,2 switching
32	33	Stall prevention switching/ Torque limit switching 1	118	119	Preset speed switching 5
34	35	Torque limit switching 2	120	121	Quick deceleration 1
36	37	PID control OFF	122	123	Quick deceleration 2
38	39	Pattern operation 1	124	125	Preliminary excitation
40	41	Pattern operation 2	126	127	Brake
42	43	Pattern operation continuation	130	131	Brake answerback
44	45	Pattern operation start	134	135	Traverse operation
46	47	External thermal trip	136	137	Rescue operation
48	49	Communication priority cancel	138	139	Pump control switching
50	51	3-wire operation hold/stop	140	141	Fwd slowdown
52	53	PID differential/integral reset	142	143	Fwd stop
54	55	PID plus/minus switching	144	145	Rev slowdown
56	57	Forced run	146	147	Rev stop
58	59	Fire speed run	148	149	Fwd/Rev slowdown
60	61	Dwell operation	150	151	Hit and stop clear
62	63	Synchronized Acc/Dec	152	153	No.2 motor switching
64	65	My function start	154	155	External PID3 enabled
66	67	Offline auto-tuning	156	157	External PID4 enabled

Parameter setting		Function	Parameter setting		Function
Positive logic	Negative logic		Positive logic	Negative logic	
68	69	Speed control gain switching	158	159	Reset 2
70	71	Servo lock	162	163	External PID3 differential/integral reset
72	73	Simple positioning	164	165	External PID3 plus/minus switching
74	75	Cumulative power monitor clear	170	171	External PID4 differential/integral reset
76	77	Trace trigger	172	173	External PID4 plus/minus switching
78	79	Light-load high-speed operation inhibited	176	177	Pump control release
80	81	Terminal FP output hold	200	201	Parameter writing locked
82	83	Terminal R1 output hold	202	203	Parameter reading locked

**Appendix 4 Output terminal function select parameters**

Table 8-5 is the function setting of 9 output terminals (including 5 option terminals).  
 Table 8-6 is the output terminal functions.

Table 8-5 Output terminal function select parameters

Title	Communication No.	Parameter name	Adjustment range (Note 1)	Default setting
F130	0130	Terminal FP function 1	0-255	6
F132	0132	Terminal FL function	0-255	10
F133	0133	Terminal R1 function 1	0-255	4
F134	0134	Terminal R2 function	0-255	254
F137	0137	Terminal FP function 2	0-255	255
F138	0138	Terminal R1 function 2	0-255	255
F159	0159	Terminal DQ11 function	0-255	254
F160	0160	Terminal DQ12 function	0-255	254
F161	0161	Terminal R4 function	0-255	254
F162	0162	Terminal R5 function	0-255	254
F163	0163	Terminal R6 function	0-255	254

Note 1: For an explanation of the adjustment range, see Table 8-6 “Output terminal functions.”

Table 8-6 Output terminal functions

Select the positive-logic of the output terminal functions for My function.

Note that negative-logic settings cannot be used for the output terminals.

Input setting	Parameter setting	Function	Operation output specifications (in case of positive logic)
1000	0	Lower limit frequency (LL)	ON: Output frequency over [LL: Lower limit frequency]
1002	2	Upper limit frequency (UL)	ON: Output frequency is [UL: Upper limit frequency] or more
1004	4	Low-speed signal	ON: Output frequency is [F100: Low-speed signal output Frequency] or more
1006	6	Acc/Dec completed	ON: Output frequency is within command frequency $\pm$ [F102: Reach signal detection band]
1008	8	Specified frequency attainment	ON: Output frequency is within [F101: Reach signal specified frequency] $\pm$ [F102: Reach signal detection band]
1010	10	Failure signal 1	ON: Tripped
1012	12	Failure signal 2	ON: At trip, except [EF], [OCL], [EPHO], and [OL2]
1014	14	Overcurrent (OC) pre-alarm	ON: Output current is [F601: Stall prevention level 1] or more
1016	16	Inverter overload (OL1) pre-alarm	ON: Calculated value of overload protection level is a specific level or more
1018	18	Motor overload (OL2) pre-alarm	ON: Calculated value of overload protection level is [F657: Overload alarm level] or more

Input setting	Parameter setting	Function	Operation output specifications (in case of positive logic)
1020	20	Overheat (OH) pre-alarm	ON: Approx. 95°C or more of IGBT element OFF: Under approx. 95°C of IGBT element (90°C or less after detection is turned on)
1022	22	Overvoltage (OP) pre-alarm	ON: Overvoltage limit in operation
1024	24	Power circuit undervoltage (MOFF) alarm	ON: Power circuit undervoltage (MOFF) detected
1026	26	Undercurrent (UC) alarm	ON: When the output current falls below the value set by [F611: Undercurrent detection level] and remains under [F611]+[F609: Undercurrent detection hysteresis] for the period of time specified by [F612: Undercurrent detection time] OFF: Output current is over [F611] ([F611]+[F609] or more after detection turns on)
1028	28	Overtorque (OT) alarm	ON: When the torque becomes [F616: Overtorque detection level during power running] or more, and remains over [F616] -[F619: Overtorque detection hysteresis] for the time specified by [F618: Overtorque detection time] OFF: Torque is under [F616] ([F616]-[F619] or less after detection turns on)
1030	30	Braking resistor overload (OLr) pre-alarm	ON: 50% or more of calculated value of [F309: Braking resistor capacity] set overload protection level
1032	32	Emergency off trip	ON: During emergency off trip ([E] is displayed)
1034	34	During retry	ON: During retry
1036	36	Pattern operation end	ON: All pattern operation end
1038	38	PID deviation limit	ON: Within the setting value of [F364: PID1 deviation upper-limit], [F365: PID1 deviation lower-limit]
1040	40	Run/Stop	ON: During run or DC braking, OFF: During stop
1042	42	Serious failure	ON: At trip *1, OFF: Other than those trip above
1044	44	Slight failure	ON: At trip ([OC1], [OC2], [OC3], [OP1], [OP2], [OP3], [OH], [OL1], [OL2], [OL3], [OLr]) OFF: Other than those trip above
1046	46	Commercial power/ Inverter Switching 1	ON: For inverter run
1048	48	Commercial power/ Inverter Switching 2	ON: For commercial power run
1050	50	During cooling fan run	ON: During cooling fan run
1052	52	During jog run	ON: During jog run
1054	54	During terminal run	ON: During terminal run, OFF: Other than terminal run
1056	56	Cumulative run time alarm	ON: Cumulative operation time is [F621: Cumulative run time alarm] or more
1058	58	Communication option communication time-out	ON: Time-out of communication option occurs (held until reset)

Input setting	Parameter setting	Function	Operation output specifications (in case of positive logic)
1060	60	Fwd/Rev run	ON: During reverse run, OFF: During forward run * Command direction or OFF during stop
1062	62	Ready for run 1	ON: Run when frequency command is ON
1064	64	Ready for run 2	ON: Run when ST, RUN, or frequency command is ON
1068	68	During brake	ON: Brake, OFF: Break release
1070	70	During alarm or pre-alarm	ON: Alarm or pre-alarm occurring
1072	72	During Fwd speed limit	ON: [F426: Fwd speed limit level] or more (Torque control)
1074	74	During Rev speed limit	ON: [F428: Rev speed limit level] or more (Torque control)
1076	76	Inverter healthy output	Output while switching ON and OFF over at every 1 sec. (to check inverter soundness)
1078	78	RS485 communication time-out	ON: RS485 communication time-out
1092	92	Designated data bit 0	ON: bit0 of FA50 is ON, OFF:bit0 of FA50 is OFF
1094	94	Designated data bit 1	ON: bit1 of FA50 is ON, OFF:bit1 of FA50 is OFF
1106	106	Light load detection 1	ON: Under heavy load torque([F335] to [F338])
1108	108	Heavy load detection	ON: Heavy load torque([F335] to [F338])or more
1110	110	During positive torque limit	ON: During positive torque limit
1112	112	During negative torque limit	ON: During negative torque limit

\*1 At trip [OCL], [OCR], [EPH1], [EPH0], [Ot], [Ot2], [OtC3], [UtC3], [OH2], [E], [EEP1]-[EEP3], [Err2]-[Err5], [UC], [UP1], [Etn], [Etn1]-[Etn3], [EF2], [PrF], [EtyP], [E-13], [E-18]-[E-21], [E-23], [E-26], [E-32], [E-37], [E-39]

Input setting	Parameter setting	Function	Operation output specifications (in case of positive logic)
1114	114	For external relay of rush current suppression	ON: For external relay of rush current suppression
1116	116	Failure signal 4	ON: During trip (including retry wait time)
1118	118	Stop positioning completion	ON: Stop position completion
1120	120	During sleep	ON: During sleep
1122	122	During synchronized Acc/Dec	ON: During synchronized acceleration/deceleration
1124	124	During traverse operation	ON: During traverse operation
1126	126	During traverse Dec	ON: During traverse deceleration
1128	128	Parts replacement alarm	ON: Any one of cooling fan, control board capacitor, or power circuit capacitor reaches parts replacement time

Input setting	Parameter setting	Function	Operation output specifications (in case of positive logic)
1130	130	Overtorque (OT) pre-alarm	ON: Torque current is 70% of [F616: Overtorque detection level during power running] setting value or more OFF: Torque current is under [F616] x 70%-[F619: Overtorque detection hysteresis]
1132	132	Frequency command 1/ Frequency command 2	ON: [F207: Frequency command select 2] enabled OFF: [FMOd: Frequency command select 1] enabled
1134	134	Failure signal 3	ON: During trip (except Emergency off)
1136	136	Hand/Auto	ON: Run command or panel run, OFF: Other than those at left
1138	138	During forced run	ON: During forced run
1140	140	During fire speed run	ON: During fire speed run
1142	142	Undertorque alarm	ON: Undertorque alarm level or more
1144	144	PID1,2 frequency command agreement	ON: Frequency commanded by [F389: PID1 set value select] and [F360: PID1 feedback input select ] are within $\pm$ [F374: PID1 set value agreement detection band]
1150	150	PTC input pre-alarm	ON: PTC thermal input value is 60% of [F646: PTC detection resistance] or more
1152	152	During Safe Torque Off (STO)	ON: Open between [STOA]-[STOB]-[PLC] OFF: Short circuit between [STOA]-[STOB]-[PLC]
1154	154	Analog input disconnecting alarm	ON: The input value of terminal [II] is [F633: II analog input disconnection detection level] or less
1156	156	Terminal F ON/OFF	ON: Terminal [F] is ON, OFF: Terminal [F] is OFF
1158	158	Terminal R ON/OFF	ON: Terminal [R] is ON, OFF: Terminal [R] is OFF
1160	160	Cooling fan replacement alarm	ON: Cooling fan reaches parts replacement time
1162	162	Number of starting alarm	ON: Number of starting is [F648: Number of starting alarm] or more
1164	164	Light load detection 2	ON: Light load detection (compatible with old model)
1166	166	During Acc	ON: During acceleration
1168	168	During Dec	ON: During deceleration
1170	170	During constant speed run	ON: During constant speed run
1172	172	During DC braking	ON: During DC braking
1174	174	During hit and stop	ON: During hit and stop
1176	176	During run including servo lock	ON: During run including servo lock
1178	178	During servo lock	ON: During servo lock
1180	180	For input cumulative power	ON: Input cumulative power unit reach
1182	182	Shock monitoring alarm	ON: Current/torque value reach the shock monitoring detection condition

Input setting	Parameter setting	Function	Operation output specifications (in case of positive logic)
1184	184	Number of external equipment starting alarm	ON: Number of starting of external equipment is [F658: Number of external equipment starting alarm] or more
1186	186	V/f switching status 1	ON: V/f switching status 1
1188	188	V/f switching status 2	ON: V/f switching status 2
1190	190	Cooling fan fault alarm	ON: Cooling fan fault
1192	192	Embedded Ethernet communication time-out	ON: Embedded Ethernet communication time-out
1194	194	Calendar 1	ON: Calendar 1
1196	196	Calendar 2	ON: Calendar 2
1198	198	Calendar 3	ON: Calendar 3
1200	200	Calendar 4	ON: Calendar 4
1202	202	During PID2 control	ON: During PID2 control
1204	204	During External PID3 control	ON: During External PID3 control
1206	206	External PID3 deviation limit	ON: Within the setting value of [A346: PID3 deviation upper-limit], [A347: PID3 deviation lower-limit]
1208	208	During External PID4 control	ON: During External PID4 control
1210	210	External PID4 deviation limit	ON: Within the setting value of [A376: PID4 deviation upper-limit], [A377: PID4 deviation lower-limit]
1212	212	Pump control	ON: For pump operation
1222	222	My function output 1	ON: My function output 1
1224	224	My function output 2	ON: My function output 2
1226	226	My function output 3	ON: My function output 3
1228	228	My function output 4	ON: My function output 4
1230	230	My function output 5	ON: My function output 5
1232	232	My function output 6	ON: My function output 6
1234	234	My function output 7	ON: My function output 7
1236	236	My function output 8	ON: My function output 8
1238	238	My function output 9	ON: My function output 9
1240	240	My function output 10	ON: My function output 10
1242	242	My function output 11	ON: My function output 11
1244	244	My function output 12	ON: My function output 12
1246	246	My function output 13	ON: My function output 13
1248	248	My function output 14	ON: My function output 14
1250	250	My function output 15	ON: My function output 15
1252	252	My function output 16	ON: My function output 16
1254	254	Always OFF	Always OFF



**Appendix 5 Internal data**

Table 8-7 is the internal data that My function can handle.

This data is not rewritable. It can be used only as input data for comparison and computation.

Table 8-7 Data that My function can handle

	Input setting	Communication No.	Function	Unit (Communication)
Monitor display output value	3000	FE00	Output frequency	0.01Hz
	3002	FE02	Frequency command value	0.01Hz
	3003	FE03	Output current	0.01%
	3004	FE04	Input voltage (DC detection)	0.01%
	3005	FE05	Output voltage	0.01%
	3015	FE15	Stator frequency	0.01Hz
	3016	FE16	Speed feedback frequency (real time)	0.01Hz
	3017	FE17	Speed feedback frequency (1-second filter)	0.01Hz
	3018	FE18	Torque	0.01%
	3019	FE19	Torque command	0.01%
	3099	FE99	Output frequency during run. Frequency command value during stop.	-
	3020	FE20	Torque current	0.01%
	3021	FE21	Exciting current	0.01%
	3022	FE22	PID feedback value	0.01Hz
	3023	FE23	Motor overload factor (OL2 data)	0.01%
	3024	FE24	Inverter overload factor (OL1 data)	0.01%
	3025	FE25	Braking resistor overload factor (OLr data)	1%
	3028	FE28	Braking resistor load factor (%ED)	1%
	3029	FE29	Input power	0.01kW
	3030	FE30	Output power	0.01kW
	3076	FE76	Input cumulative power	[F749] setting
	3077	FE77	Output cumulative power	[F749] setting
	3035	FE35	Terminal RR input value	0.01%
	3036	FE36	Terminal RX input value	0.01%
	3037	FE37	Terminal II input value	0.01%
	3094	FE94	Motor speed command	-
	3040	FE40	Terminal FM output value	0.01
	3041	FE41	Terminal AM output value	0.01
	3066	FE66	Slot A option CPU version	-
	3067	FE67	Slot B option CPU version	-
3026	FE26	Motor load factor	-	

	Input setting	Communication No.	Function	Unit (Communication)
Monitor display output value	3027	FE27	Inverter load factor	-
	3070	FE70	Inverter rated current	-
	2068	FE68	Slot C option CPU version	-
	3091	FE91	Embedded Ethernet CPU version	-
	3038	FE38	Terminal AI4 input value	0.01%
	3039	FE39	Terminal AI5 input value	0.01%
	3060	FE60	My function monitor output 1	-
	3061	FE61	My function monitor output 2	-
	3062	FE62	My function monitor output 3	-
	3063	FE63	My function monitor output 4	-
	3048	FE48	PID result frequency	0.01Hz
	3058	FE58	PID set value	0.01Hz
	3031	FE31	Pattern operation group number	0.1
	3032	FE32	Pattern operation remaining cycle number	1
	3033	FE33	Pattern operation preset speed number	1
	3034	FE34	Pattern operation remaining time	0.1
	3071	FE71	Inverter rated voltage	0.1
	3090	FE90	Motor speed (estimated value)	1
	3056	FE56	Terminal S4/S5 pulse train input value	0.01%
	3081	FE81	Connected option number	1
	3080	FE80	Cumulative power ON time	-
	3059	FE59	External equipment counter	-
	3083	FE83	Internal temperature 1	-
	3078	FE78	Power circuit board temperature	-
	3096	FE96	External PID4 set value	-
	3097	FE97	External PID4 feedback value	-
	3098	FE98	External PID4 result value	-
	2000	FD00	Output frequency	0.01Hz
	2002	FD02	Frequency command value	0.01Hz
	2003	FD03	Output current	0.01%
	2004	FD04	Input voltage (DC detection)	0.01%
	2005	FD05	Output voltage	0.01%
2015	FD15	Stator frequency	0.01Hz	
2016	FD16	Speed feedback frequency (real time)	0.01Hz	
2017	FD17	Speed feedback frequency (1-second filter)	0.01Hz	
2018	FD18	Torque	0.01%	
2019	FD19	Torque command	0.01%	

	Input setting	Communication No.	Function	Unit (Communication)
Monitor display output value	2099	FD99	Output frequency during run. Frequency command value during stop.	-
	2020	FD20	Torque current	0.01%
	2021	FD21	Exciting current	0.01%
	2022	FD22	PID feedback value	0.01Hz
	2023	FD23	Motor overload factor (OL2 data)	0.01%
	2024	FD24	Inverter overload factor (OL1 data)	0.01%
	2025	FD25	Braking resistor overload factor (OLr data)	1%
	2028	FD28	Braking resistor load factor (%ED)	1%
	2029	FD29	Input power	0.01kW
	2030	FD30	Output power	0.01kW
	2094	FD94	Motor speed command	-
	2026	FD26	Motor load factor	-
	2027	FD27	Inverter load factor	-
	2070	FD70	Inverter rated current (with carrier frequency correction )	-
	2081	FD81	Actual carrier frequency	-
	2043	FD43	Terminal FP pulse train output value	-
	2048	FD48	PID result frequency	0.01Hz
	2058	FD58	PID set value	0.01Hz
	2050	FD50	Light-load high-speed switching load torque	0.01%
	2051	FD51	Light-load high-speed torque during constant speed run	0.01%
	2090	FD90	Motor speed (estimated value)	1
	2085	FD85	My function COUNT1	1
	2086	FD86	My function COUNT2	1
	2087	FD87	Dancer control PID result frequency	0.01Hz
	2091	FD91	My function COUNT3	1
	2092	FD92	My function COUNT4	1
	2093	FD93	My function COUNT5	1
	2041	FD41	Cumulative cooling fan run time	-
	2014	FD14	Cumulative run time	-
	2031	FD31	Cumulative overcurrent time	-
	2032	FD32	Number of starting	-
	2033	FD33	Number of Fwd starting	-
	2034	FD34	Number of Rev starting	-
	2035	FD35	Number of trip	-
	2036	FD36	Number of serious failure trip	-

	Input setting	Communication No.	Function	Unit (Communication)
Monitor display output value	2037	FD37	Number of slight failure trip	-
	2038	FD38	Number of specified trip 1	-
	2039	FD39	Number of specified trip 2	-
	2040	FD40	Number of specified trip 3	-
	2083	FD83	Internal temperature 1	-
	2096	FD96	External PID3 set value	-
	2097	FD97	External PID3 feedback value	-
	2098	FD98	External PID3 result value	-
	4051	FA51	Communication data output	-
	4015	FA15	Communication option Receiving counter	1
	4016	FA16	Communication option Abnormal counter	1
	4025	FA25	Embedded Ethernet Transmission counter	1
	4017	FA17	Embedded Ethernet Receiving counter	1
	4018	FA18	Embedded Ethernet Abnormal counter	1
FM/AM output Pulse train output	2000	FD00	Output frequency	0.01Hz
	2002	FD02	Frequency command value	0.01Hz
	2003	FD03	Output current	0.01%
	2004	FD04	Input voltage (DC detection)	0.01%
	2005	FD05	Output voltage	0.01%
	2015	FD15	Stator frequency	0.01Hz
	2016	FD16	Speed feedback frequency (real time)	0.01Hz
	2017	FD17	Speed feedback frequency (1-second filter)	0.01Hz
	2018	FD18	Torque	0.01%
	2019	FD19	Torque command	0.01%
	2099	FD99	Output frequency during run. Frequency command value during stop.	-
	2020	FD20	Torque current	0.01%
	2021	FD21	Exciting current	0.01%
	2022	FD22	PID feedback value	0.01Hz
	2023	FD23	Motor overload factor (OL2 data)	0.01%
	2024	FD24	Inverter overload factor (OL1 data)	0.01%
	2025	FD25	Braking resistor overload factor (OLr data)	1%
	2028	FD28	Braking resistor load factor (%ED)	1%
	2029	FD29	Input power	0.01kW
	2030	FD30	Output power	0.01kW
3035	FE35	Terminal RR input value	0.01%	
3036	FE36	Terminal RX input value	0.01%	
3037	FE37	Terminal II input value	0.01%	

	Input setting	Communication No.	Function	Unit (Communication)
FM/AM output Pulse train output	2094	FD94	Motor speed command	-
	2026	FD26	Motor load factor	-
	2027	FD27	Inverter load factor	-
	2043	FD43	Terminal FP pulse train output value	1pps
	3038	FE38	Terminal AI4 input value	0.01%
	3039	FE39	Terminal AI5 input value	0.01%
	3060	FE60	My function monitor output 1	1
	3061	FE61	My function monitor output 2	1
	3062	FE62	My function monitor output 3	1
	3063	FE63	My function monitor output 4	1
	2048	FD48	PID result frequency	0.01Hz
	2058	FD58	PID set value	0.01Hz
	2050	FD50	Light-load high-speed switching load torque	0.01%
	2051	FD51	Light-load high-speed torque during constant speed run	0.01%
	2090	FD90	Motor speed (estimated value)	1
	3056	FE56	Terminal S4/S5 pulse train input value	0.01%
	2087	FD87	Dancer control PID result frequency	0.01Hz
	2083	FD83	Internal temperature 1	1 degree C
	3078	FE78	Power circuit board temperature	1 degree C
	2096	FD96	External PID3 set value	0.01Hz
	2097	FD97	External PID3 feedback value	0.01Hz
	2098	FD98	External PID3 result value	0.01Hz
	3096	FE96	External PID4 set value	0.01Hz
	3097	FE97	External PID4 feedback value	0.01Hz
	3098	FE98	External PID4 result value	0.01Hz

**Appendix 6 Examples of computing function settings**

In the computing functions listed in Appendix 2, this chapter explains in detail the timer function, counter function, peak hold function, set & reset function, and clear function, and gives examples of their settings.

■ **Input function command 14: ON (ON timer), 23: ON2 (ON timer 2)**

When the input signal is turned ON, the ON command delays the timing of putting out an ON signal by the setting time of the ON timer, as shown in the figure below. The timer is turned on only when it receives an ON signal, as illustrated in the timing chart, so no ON signal is put out when the input signal ON time is shorter than the timer ON time (time during which the timer is activated). Conversely, when the input signal is turned OFF, an OFF signal is put out immediately and the timer is reset.

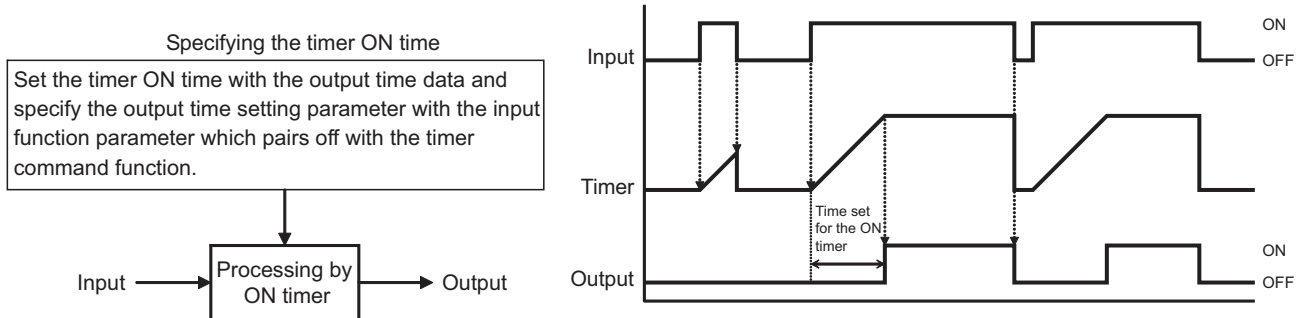
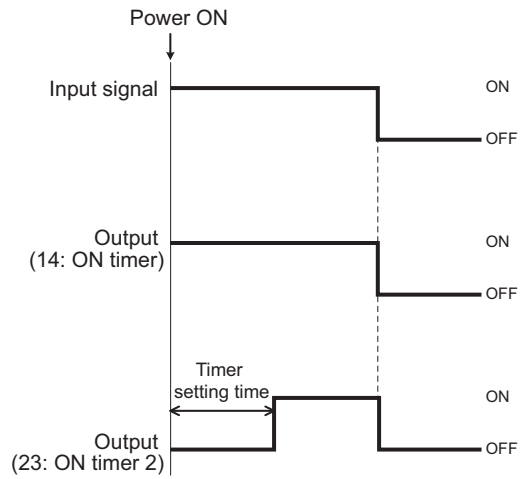

Fig. 8-1 Processing by ON timer

**Example:** Input a signal to the Terminal [S1], and output the signal from the Terminal [R1] with 1 second of delay time (timer ON time).

		Title	Parameter setting	Description
Prior setting	-	A977	0 (Default)	Set to "0: Disabled" of My function.
		F114	0	Assign the "no function" to the Terminal [S1].
		F133	222	Assign the My function output 1 to the Terminal [R1].
		A928	1.0	Set a delay time (timer ON time) of 1.0 second for the output time data 1.
Unit 1	Step 1	A900	4	Load the Terminal [S1] input signal. (LD S1)
	Step 2	A901	14	Activate the ON timer set by [A928].
		A902	928	
	Step 3	A903	0 (Default)	NOP command (no operation)
		A904	0 (Default)	
Step 4	A905	1222	Store the result to the My function output 1.	
-	-	A977	2	Set to "2: Always active" of My function.

\*Difference between ON (ON timer) and ON2 (ON timer 2)  
The operation of above 2 commands is different in case the signal is already ON when the power is ON.



■ Input function command 15: OFF (OFF timer), 24: OFF2 (OFF timer 2)

When the input signal is turned OFF, the OFF command delays the timing of putting out an OFF signal by the setting time of the OFF timer, as shown in the figure below. The timer is activated only when it receives an OFF signal, as illustrated in the timing chart.

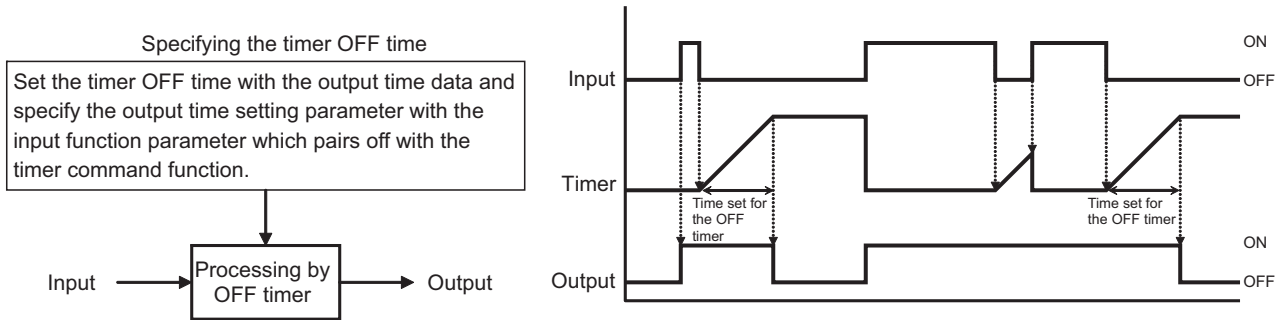

Fig. 8-2 Processing by OFF timer

**Example:** Input a signal to the Terminal [S1], and output of the Terminal [R1] is retained for 1 second.

		Title	Parameter setting	Description
Prior setting	-	A977	0 (Default)	Set to "0: Disabled" of My function.
		F114	0	Assign the "no function" to the Terminal [S1].
		F133	222	Assign the My function output 1 to the Terminal [R1].
		A928	1.0	Set a delay time (timer OFF time) of 1.0 second for the output time data 1.
Unit 1	Step 1	A900	4	Load the Terminal [S1] input signal. (LD S1)
	Step 2	A901	15	Activate the OFF timer set by [A928]
		A902	928	
	Step 3	A903	0 (Default)	NOP command (no operation)
		A904	0 (Default)	
Step 4	A905	1222	Store the result to the My function output 1.	
-	-	A977	2	Set to "2: Always active" of My function.

\*Difference between OFF (OFF timer) and OFF2 (OFF timer 2)

The operation of above 2 commands is different in case the signal is already ON when the power is ON.

**Note:** In case of OFF timer 2, please note that output is ON when the power is ON even though input signal is OFF.

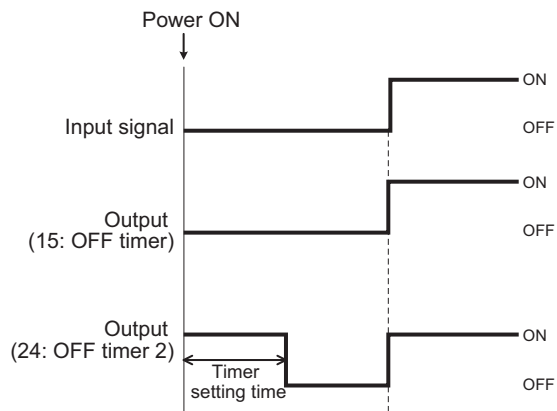



■ Input function command 16: COUNT 1, 17: COUNT 2, 25: COUNT3, 26: COUNT 4, 27: COUNT 5 (counter)

COUNT1, COUNT2, COUNT3, COUNT4 and COUNT5 commands make the inverter count the number of times the input signal is turned on and off, as shown in the figure below, and put out a signal when reaching the specified count. The count is reset to zero using the signal specified with the input function parameter which pairs off with the count command parameter. Note that this command has no relation to the SET and RESET commands described later.

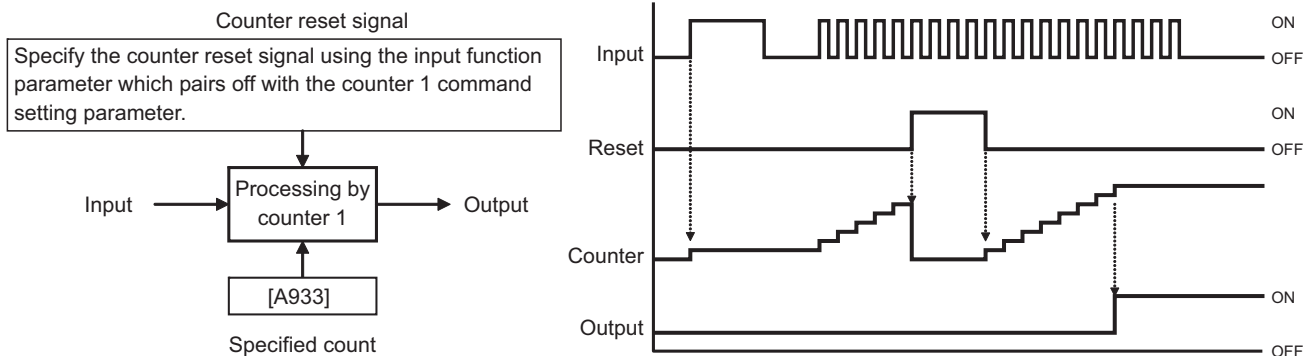

Fig. 8-3 Processing by counter

- Note 1: Specify a pulse width of at least 5 ms for both ON and OFF pulse input signals.
- Note 2: RESET commands have priority over COUNT commands. Therefore, if a reset command is entered instantly the specified count has been reached, the count is reset to zero and no signal is put out.
- Note 3: This command cannot be used in plural. Even if do so, that will not result in an intended operation.

**Example:** Input count signal from Terminal [S1] and input reset signal from Terminal [S2].  
Output the signal from Terminal [R1] with the count of 10 times.

		Title	Parameter setting	Description
Prior setting	-	A977	0 (Default)	Set to "0: Disabled" of My function.
		F114	0	Assign the "no function" to the Terminal [S1].
		F115	0	Assign the "no function" to the Terminal [S2].
		F133	222	Assign the My function output 1 to the Terminal [R1].
		A933	10	Set the count of 10 times for COUNT 1.
Unit 1	Step 1	A900	4	Load the Terminal [S1] input signal (LD S1)
	Step 2	A901	16	Count the number of pulse signals from the Terminal [S1].
		A902	5	Assign the reset signal output function to the Terminal [S2].
	Step 3	A903	0 (Default)	NOP command (no operation)
		A904	0 (Default)	
Step 4	A905	1222	Store the result to the My function output 1.	
-	-	A977	2	Set to "2: Always active" of My function.

Input function command 17,25,26 and 27 are same function as COUNT 1.

■ Input function command 18: HOLD (peak hold)

The HOLD command makes the inverter hold the peak value of analog input signal and monitor date, as illustrated in the timing chart below.

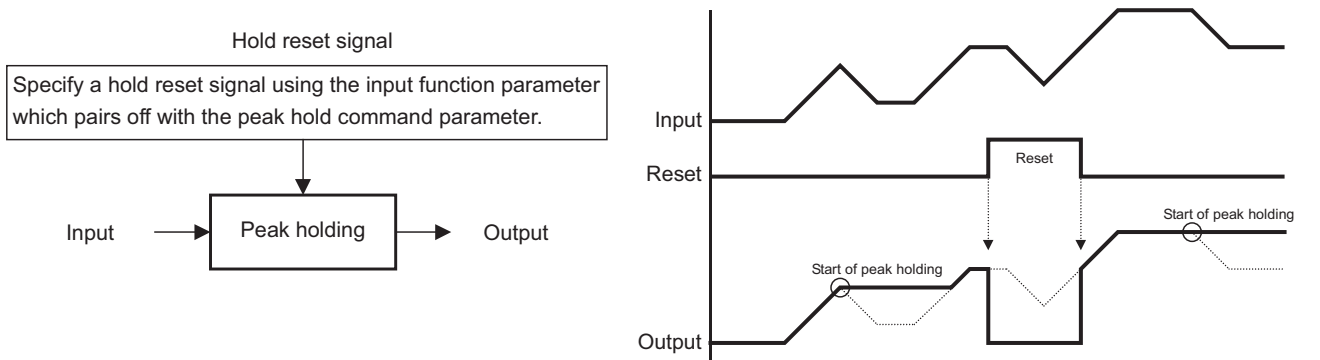

Fig. 8-4 Processing by peak hold

**Example:** Hold the peak output current. When the output current is over 120% of the rated current, output the signal from the Terminal [R1]. Reset the hold by the signal from the Terminal [S1].

		Title	Parameter setting	Description
Prior setting	-	A977	0 (Default)	Set to "0: Disabled" of My function.
		F114	0	Assign the "no function" to the Terminal [S1].
		F133	222	Assign the My function output 1 to the Terminal [R1].
		A918	120	Assign a reference value of 120% to the output percent data 1.
Unit 1	Step 1	A900	3003	Load the output current. (LD Output current)
	Step 2	A901	18	Start holding the peak output current.
		A902	4	Assign the reset signal output function to the Terminal [S1].
	Step 3	A903	9	Output a signal when the peak value reaches 120% of the rated current.
		A904	918	
Step 4	A905	1222	Store the result to the My function output 1.	
-	-	A977	2	Set to "2: Always active" of My function.

- Input function command 19: SET
- Input function command 20: RESET

The SET command turns on (sets) the output signal when the input signal is turned on, as shown in the figure below, and holds the output signal ON even if the input signal is turned off. The RESET command is used to turn off the output signal.

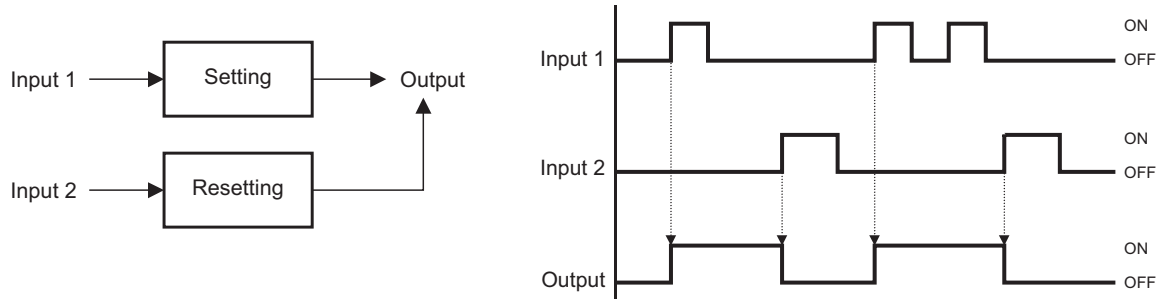

Fig. 8-5 Setting and resetting

**Example:** Output the input signal from the Terminal [F] to the Terminal [R1] as the hold signal by using SET command. Reset the output signal by the signal from the Terminal [S1].

		Title	Parameter setting	Description
Prior setting	-	A977	0 (Default)	Set to "0: Disabled" of My function.
		F111	0	Assign the "no function" to the Terminal [F].
		F114	0	Assign the "no function" to the Terminal [S1].
		F133	222	Assign the My function output 1 to the Terminal [R1].
Unit 1	Step 1	A900	1	Load the Terminal [F] input terminal signal. (LD F)
	Step 2	A901	19	Send a signal to the My function output 1 by the SET command, and output a hold signal from the Terminal [R1].
		A902	1222	
	Step 3	A903	0 (Default)	NOP command (no operation)
		A904	0 (Default)	
Step 4	A905	0 (Default)	NOP command (no operation)	
Unit 2	Step 1	A906	4	Load the Terminal [S1] input terminal signal. (LD S1)
	Step 2	A907	20	Cancel the hold command of the My function output 1 by the RESET command.
		A908	1222	
	Step 3	A909	0 (Default)	NOP command (no operation)
		A910	0 (Default)	
Step 4	A911	0 (Default)	NOP command (no operation)	
-	-	A977	2	Set to "2: Always active" of My function.

- Input function command 21: CLR (clear)
- Input function command 22: CLRN (clear (inversion))

The CLR command turns off the input signal set by My function when the clear signal is turned on, as shown in the figure below. The CLRN command turns off the input signal when the clear signal is turned off.

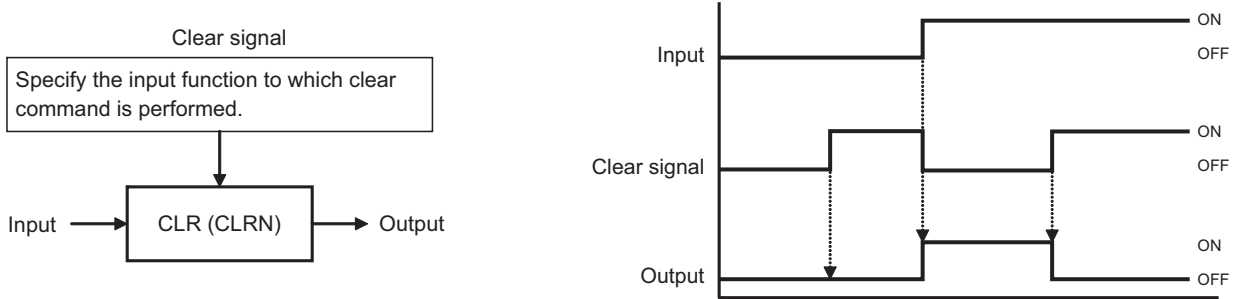

Fig. 8-6 Processing by clear

**Example:** Turn off the input signal from the Terminal [F] by the clear command from the Terminal [R].

		Title	Parameter setting	Description
Prior setting	-	A977	0 (Default)	Set to "0: Disabled" of My function.
		F111	0	Assign the "no function" to the Terminal [F].
		F112	0	Assign the "no function" to the Terminal [R].
		F133	222	Assign the My function output 1 to the Terminal [R1].
Unit 1	Step 1	A900	1	Load the Terminal [F] input terminal signal. (LD F)
	Step 2	A901	21	CLR command for the Terminal [F].
		A902	2	Assign the CLR command to the Terminal [R]
	Step 3	A903	0 (Default)	NOP command (no operation)
		A904	0 (Default)	
Step 4	A905	1222	Store the result to the My function output 1.	
-	-	A977	2	Set to "2: Always active" of My function.

